



# SUBMITTAL STANDARD NO-HUB COUPLINGS

\_\_\_\_\_

Date

\_\_\_\_\_

Architect

\_\_\_\_\_

Project

\_\_\_\_\_

Contractor

\_\_\_\_\_

Engineer

**PROFLO patented No-Hub Couplings** are engineered to connect no-hub cast iron pipe in applications replacing the less-efficient hub & spigot material. The couplings consists of an elastomeric compound gasket (ASTM C-564) housed inside a 301 stainless steel corrugated shield. Depending on the size of the shield, (2) or (4) 301 stainless steel clamps surround the shield and provide the sealing force. The 5/16" hex-head screws are made from 305 stainless steel. The PROFLO Standard No-Hub Couplings are available in sizes ranging from 1 1/2" – 10". The couplings are designed for installation torque of 60 in-lbs. The entire coupling is corrosion resistant.

<b>Standard No - Hub Couplings</b>			
Size	Part No.	Installation Torque Inch Pounds	No. of Clamps Per Coupling
1-1/2"	PFNHCJ	60	2
2"	PFNHCK	60	2
3"	PFNHCM	60	2
4"	PFNHCP	60	2
5"	PFNHCS	60	4
6"	PFNHCU	60	4
8"	PFNHCX	60	4
10"	PFNHC10	60	4
2" X 1-1/2"	PFNHRCKJ	60	2
3" x 2"	PFNHRCKK	60	2
4" x 3"	PFNHRCKM	60	2

### ***The Design***

The PROFLO Standard No-Hub Coupling is engineered to provide superior performance at a very competitive cost. Conforms to ASTM C1277.

### ***The Gasket***

Made from high-quality elastomeric compound (ASTM C-564), the PROFLO No-Hub gasket features multiple sealing beads under the clamp bands. The sealing beads on the gasket impede the movement of the gasket and pipe, providing a positive, reliable seal.

### ***The Shield***

0.007" thick type 301 stainless steel shield requires less band load to transfer pressure to the gasket, leaving more clamping load in reserve to compress the gasket. The patented, bi-directional corrugations create clamp sealing pressure in both parallel and transverse patterns on the gasket and pipe, thereby avoiding pull-out failures, and providing a positive, reliable seal.

### ***The Clamps***

Standard 301 stainless steel clamps and 5/16" hex-head 305 screws provide the sealing force. 1-1/2" through 4" couplings use two (2) clamps; 5" through 10" couplings use four (4) clamps. The entire assembly is corrosion resistant.

**STANDARD NO-HUB COUPLINGS**  
**Product Information Submittal**  
**for No-Hub Systems**

<b>TEST</b>	<b>GASKET PHYSICAL TEST MIN. OR MAX. REQUIREMENTS</b>	<b>ASTM METHOD</b>
Tensile Strength	1500 psi min.	D 412
Elongation	250 min.	D 412
Durometer (Shore A)	70 +/-5 @ 76°F +/- 5°F	D 2240
Accelerated Aging	15% maximum tensile and 20% maximum elongation, 10 points maximum increase in hardness, all determinations after oven aging for 96 hours at 158°F	D573
Compression Set	25% max. after 22 hours at 158°F	D 395 Method B
Oil Immersion	80% max. volume change after immersion in IRM 903 for 70 hours at 212°F.	D 471
Ozone Cracking	No visible cracking at 2 times magnification of the gasket after 100 hours exposure in 1.5 ppm ozone concentration at 104°F. Testing and inspection to be on gasket which is loop mounted to give approximately 20% elongation of outer surface.	D 1149
Tear Resistance	150 lbf /in. min.	D 624
Water Absorption	20% max. by weight after 7 days at 158°F	D 471

<b>MATERIALS</b>	
Clamp:	Type 301 AISI stainless steel
Screw:	Type 305 AISI stainless steel 5/16" hex head/shoulder
Shield:	Type 301 AISI stainless steel, corrugated. Shield thickness 0.007"
Gasket:	The gasket is made of an elastomeric compound that meets the requirements of ASTM C-564.

The PROFLO patented No-Hub Coupling has been engineered to provide an all stainless steel coupling; balancing the desire for a more rigid joint with the need to provide a superior, positive, reliable seal which can accommodate possible disparities in the mating of No-Hub pipe and fittings.

The 1-1/2", 2", 3" and 4" diameter couplings consist of a 2 1/8" wide bi-directional, corrugated 301 stainless steel shield in conjunction with two (2) stainless steel clamps mounted in a series, secured in place by means of fixed and "floating" eyelets to allow the clamp "travel" during tightening. The 5" and 6" couplings consist of a 3" wide corrugated 301 stainless steel shield in conjunction with four (4) clamps and the 8" and 10" coupling consists of a 4" wide corrugated 301 stainless steel shield with four (4) stainless steel clamps.

All PROFLO standard no-hub couplings are designed to be installed with a pre-set torque wrench calibrated at 60 in-lbs. to accommodate the 305 stainless steel 5/16" hex-head/shoulder screw.

# STANDARD NO-HUB COUPLINGS



## POLYCHLOROPRENE (NEOPRENE) GASKET

With NSF Certified couplings, you can be assured the gasket component is made out of a properly vulcanized virgin compound where the primary elastomer is polychloroprene (neoprene). Polychloroprene withstands high liquid temperatures (up to 212° F), is fire and oil resistant, and resists decay and deterioration when exposed to effluents in the pipe, air or soil.

## SPECIALY BEADED GASKETS

The specially beaded gasket combines with the shield and clamping forces for superior sealing pressure and holding power.

## MECHANICAL INTERLOCKING CLAMP DESIGN

PROFLO™ Couplings feature a one-piece screw housing that mechanically interlocks the housing to the band. This one-piece housing design eliminates leak paths that can occur in stacked or welded clamps.

## RECTANGULAR BAND NOTCHES

With our rectangular notch design, there is a larger radius at either end of the rectangular notch, reducing the probability of stress cracking. There is also more solid band (land area) between the notches with a rectangular notch design. The greater the land area, the greater the band strength.

## FLOATING EYELET DESIGN

Floating eyelets fasten the clamps to the shield, allowing the clamp band and shield to move independently. This freedom prevents the shield from crimping during tightening, which can lead to leakage.



## NSF CERTIFIED

NSF International is the world leader in standards development and product certification. With this certification, you'll have peace of mind that the PROFLO™ Standard Couplings are fully certified to CISPI 310 and ASTM C564. Before the NSF certification, it was difficult to verify couplings were compliant with the CISPI 310 standard. Now just look for the blue NSF mark and you'll always be in compliance.

## CISPI 310, ASTM C564 AND ASTM C1277

PROFLO™ Standard Couplings are certified by all major plumbing code bodies throughout the U.S. and Canada, and conform to the most stringent industry standards: CISPI 310, ASTM C564, and ASTM C1277.

## 300 GRADE STAINLESS STEEL COMPONENTS

Premium-grade stainless steel components provide superior corrosion resistance, reliability and durability over time in both above-ground and below-ground applications.

## TORQUE RATING

Installation (60 inch-pounds) and Ultimate (75 inch-pounds) torque ratings are engineered to provide the clamps with enough tightening capacity to ensure that ample sealing pressure reaches the joint to affect a tight, secure seal.

# STANDARD NO-HUB COUPLINGS



**PROFLO™ Clamps**  
1/2" and 9/16" band widths with 5/16" hex-head screw applies 60 in.-lbs. of installation torque to the band/shield assembly.



**Specially Beaded Gaskets**  
The PROFLO™ standard no-hub coupling utilizes a specially beaded gasket that combines with the shield and clamping forces for superior sealing pressure and holding power.



**Floating Eyelet Design**  
Floating eyelets fasten the clamps to the shield, allowing the clamp band and shield to move independently. This freedom prevents the shield from crimping during tightening, which can lead to leakage later on.

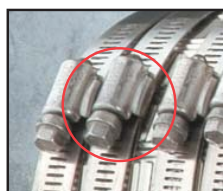

**Mechanical Interlocking Clamp Design**  
PROFLO™ clamps feature a one-piece screw housing that mechanically interlocks the housing to the band. This one-piece housing design eliminates leak paths that can occur in staked or welded clamps.

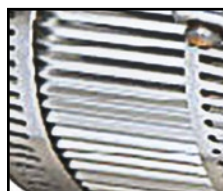

**Shield Design**  
The Proflo standard duty couplings utilize a "Classic" shield configuration with corrugations that run perpendicular to the clamp bands. This design allows maximum transfer of sealing pressure to the pipe surface, even when pipes of dissimilar outside diameters are being joined due to variations in wall thickness. When tightening

the hose clamps, these corrugations will fold uniformly around the circumference of the pipe. This ensures a consistent wrinkle free wrap of the of the underlying gasket against the pipe surface without any leak paths for a positive, reliable seal.

Features	PROFLO Standard No-Hub Couplings
1/2" Clamp Band	1-1/2" thru 4"
9/16" Clamp Band	5" thru 10"
5/16" Hex Head Screw	✓
No. of Clamps Included	2 (1-1/2" thru 4") 4 (5" thru 10")
Coupling Width	1-1/2" thru 4" = 2-1/8" 5" & 6" = 3" 8" & 10" = 4"
Shield Color	None
Bi-Directional Shield	Unidirectional
Beaded Gasket	✓
Floating Eyelets	✓
Interlocked Housing Design	✓
Shield Material	301 SS
Band Material	301 SS
Housing Material	301 SS
Screw Material	305 SS
Eyelet Material	305 SS
Gasket Material	ASTM C564 Compliant
Installation Torque	60 in-lbs
Ultimate Torque	75 in-lbs
CISPI 310 Compliant	✓
ASTM C1277 Compliant	✓
IAPMO	Certified
Canadian Std Association	Certified
NSF	Certified 1-1/2" thru 10" Excludes reducer couplings
Massachusetts Approval	✓

\*U.S. Patent No. 5,431,458

# STANDARD NO-HUB COUPLINGS



**Description:** Couplings consist of gasket and shield assemblies. The shield assemblies have two to four clamps depending on the size. The clamps are fastened with eyelets to the bi-directional corrugated shield.

**Materials:** Steels used in couplings are stainless steels. Shields, bands and housings are AISI 301. Screws and eyelets are AISI 305. Gaskets are made from an elastomeric compound that meets the requirements of ASTM C564.

**Specifications:** Couplings conform to CISPI 310. Couplings comply with ASTM C564, ASTM C1277, IAPMO file #3198, Commonwealth of Massachusetts CMR-248 and City of New York MEA 253-98-E. Gaskets are made from an elastomeric compound that meets the requirements of ASTM C564.

**Service temperature:** From -22 to 250 degrees F (-30 to 121C)

## PROFLO™ Standard No-Hub Couplings

Size	Part No.	Installation Torque (inch-pounds)	No. of Clamps Per Coupling
1-1/2"	PFNH CJ	60	2
2"	PFNH CK	60	2
3"	PFNH CM	60	2
4"	PFNH CP	60	2
5"	PFNH CS	60	4
6"	PFNH CU	60	4
8"	PFNH CX	60	4
10"	PFNH C10	60	4
2" x 1-1/2"	PFNHR CKJ	60	2
3" x 2"	PFNHR CMK	60	2
4" x 3"	PFNHR CPM	60	2

Dimensions		
Pipe Size	Min.	Max.
1-1/2"	1.50	2.50
2"	2.00	3.00
3"	3.00	4.00
4"	4.00	5.00
5"	5.30	6.20
6"	6.30	7.20
8"	8.30	9.20
10"	10.45	11.35

### Shield and Clamp Assembly

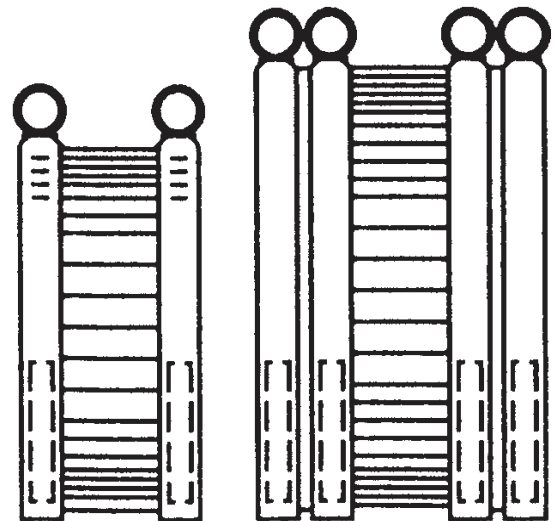

Sizes  
1-1/2" thru 4"

Tighten clamps alternately to recommended torque.

Sizes  
5" thru 10"

Tighten inside clamps first, then outside clamps.



To be used with Raptor™  
**RAP18550 Torque Wrench**

Made in Mexico



# Cast Iron

DC-CI

**CHARLOTTE**  
PIPE AND FOUNDRY COMPANY

DIMENSIONAL CATALOG

**No-Hub Pipe and Fittings**

**Service Pipe and Fittings**

**Extra Heavy Pipe and Fittings**

**Plugs**

[Updated January 1, 2016]

**You can't beat the system.®**

© 1977-2016 Charlotte Pipe and Foundry Company

# Cast Iron Pipe and Fitting Dimensions

## Table of Contents

	<u>Page</u>
No-Hub Pipe Dimensions .....	3&5
No-Hub Fitting Dimensions.....	4-43
No-Hub Starter Fitting Detail Drawings .....	44-50
Service Pipe Dimensions .....	51-53
Service Fitting Dimensions .....	54-102
Extra Heavy Pipe Dimensions .....	103-105
Extra Heavy Fitting Dimensions.....	106-119
Plug Dimensions.....	120
Certification .....	121
Warranty .....	123



Download our Tech Tools App for dimensional info, tech calculators and more on your mobile device.

# No-Hub

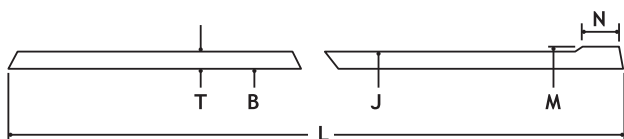

**TABLE 1**  
**DIMENSIONS AND TOLERANCES (IN INCHES) OF SPIGOTS**  
**AND BARRELS FOR NO-HUB PIPE AND FITTINGS**

Size	Inside Barrel Diameter	Outside Diameter Barrel	Outside Diameter Spigot	Width Spigot Bead N	Thickness of Barrel		Gasket Positioning Lug
	B	J	M	(± .13)	T-Nom.	T-Min.	W
1 1/2	1.50 ± .09	1.90 ± .06	1.96 ± .06	.25	.16	.13	1.13
2	1.96 ± .09	2.35 ± .09	2.41 ± .09	.25	.16	.13	1.13
3	2.96 ± .09	3.35 ± .09	3.41 ± .09	.25	.16	.13	1.13
4	3.94 ± .09	4.38 ± .09	4.44 ± .09	.31	.19	.15	1.13
5	4.94 ± .09	5.30 ± .09	5.36 ± .09	.31	.19	.15	1.50
6	5.94 ± .09	6.30 ± .09	6.36 ± .09	.31	.19	.15	1.50
8	7.94 ± .13	8.38 ± .09	8.44 ± .09	.31	.23	.17	2.00
10	10.00 ± .13	10.56 ± .09	10.62 ± .09	.31	.28	.22	2.00
12	11.94 ± .09	12.50 ± .13	12.62 ± .13	.31	.28	.22	2.75
15	15.11 ± .09	15.83 ± .13	16.12 ± .13	.31	.36	.30	2.75

## TEN FOOT PIPE BUNDLES NO-HUB PIPE

Size	Pieces	Weight	Height
1 1/2" x 10'	72	2052	12"
2" x 10'	54	1906	11"
3" x 10'	36	1944	14"
4" x 10'	27	1922	17"
5" x 10'	24	2342	20"
6" x 10'	18	2120	23"
8" x 10'	8	1367	22"
10" x 10'	6	1528	26"
12" x 10'	6	1908	29"
15" x 10'	2	985	19"

Weights are approximate and are for shipping purposes only.

**PART NO. NH 1**

**No-Hub (Standard) Coupling**

Size	Shield Width	Number of Clamps
1½	2.13"	2
2 x 1½	2.13"	2
2	2.13"	2
3 x 2	2.13"	2
3	2.13"	2
4 x 3	2.13"	2
4	2.13"	2
5	3.00"	4
6	3.00"	4
8	4.00"	4
10	4.00"	4



**PART NO. MDC 2**

**Heavy Duty (MD) Coupling**

Size	Shield Width	Number of Clamps
1½	3.00"	4
2	3.00"	4
3	3.00"	4
4	3.00"	4
5	4.00"	6
6	4.00"	6
8	4.00"	6
10	4.00"	6



**PART NO. SDC 4**

**Heavy Duty (HD) Coupling**

Size	Shield Width	Number of Clamps
1½	3.00"	4
2	3.00"	4
3	3.00"	4
4	3.00"	4
5	4.00"	6
6	4.00"	6
8	4.00"	6
10	4.00"	6



**PART NO. HD 1**

**Heavy Duty Coupling**

Size	Shield Width	Number of Clamps
12	5.50"	6
15	5.50"	6



**PART NO. NH 2**

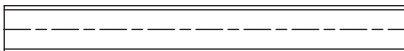

**No-Hub Pipe - Ten Feet Laying Length**

Size	Weight
1½" x 10'	28.5
2" x 10'	35.0
3" x 10'	54.0
4" x 10'	71.2
5" x 10'	97.6
6" x 10'	117.8
8" x 10'	170.9
10" x 10'	254.6
12" x 10'	318.1
15" x 10'	492.6

**PART NO. NH 4**

**Quarter Bend**

Size	D	Weight
1½	4¼	1.7
2	4½	2.2
3	5	3.7
4	5½	6.5
5	6½	9.3
6	7	15.0
8	8½	23.1
4 x 3	5½	5.5

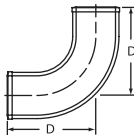

**Long Quarter Bend**

Size	D	E	Weight
2 x 12	12	4½	5.4
2 x 18	18	4½	8.8
2 x 24	24	4½	10.7
3 x 12	12	5	8.5
4 x 12	12	5½	11.2

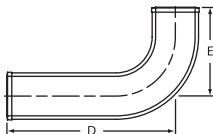

N O - H U B

**PART NO. NH 4A**

**Tapped Quarter Bend**

Size	D	E	Weight
1½ x 1½	3	2	1.9
2 x 1¼	3¼	2¼	2.0
2 x 1½	3¼	2¼	1.8
2 x 2	3¼	2¼	2.9



**PART NO. NH 6**

**Quarter Bend with Side Opening**

Size	E	D	Weight
3 x 2	3¼	4	5.1
4 x 2	3¾	4 <sup>5</sup> / <sub>16</sub>	7.5

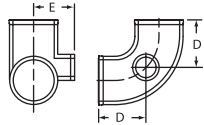

**PART NO. NH 8**

**Quarter Bend with Heel Opening**

Size	D	E	Weight
3 x 2	5	2 <sup>7</sup> / <sub>8</sub>	5.6
4 x 2	5½	3¼	7.2

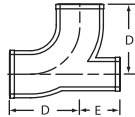

**PART NO. NH 8A**

**Double Quarter Bend**

Size	D	Weight
2	4½	4.5
3	5	7.1
4	5½	9.7

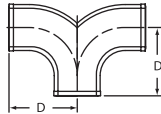

**PART NO. NH 8B**

**Extended Quarter Bend  
with Low Heel Outlet**

Size	D	E	Weight
3 x 2	5	10 1/2	7.8

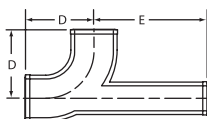

**PART NO. NH 9**

**Fifth Bend**

Size	D	Weight
2	3 11/16	2.3
3	4 1/16	3.7
4	4 7/16	6.1

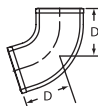

**PART NO. NH 10**

**Sixth Bend**

Size	D	Weight
2	3 1/4	2.2
3	3 1/2	3.0
4	3 13/16	5.3

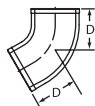

**PART NO. NH 12**

**Eighth Bend**

Size	D	Weight
1 1/2	2 5/8	1.5
2	2 3/4	1.5
3	3	2.9
4	3 1/8	4.0
5	3 7/8	7.4
6	4 1/16	9.1
8	5	14.9
10	5 15/16	31.7
12	6 9/16	31.6
15	7 13/16	62.0



**PART NO. NH 12**

**Long Eighth Bend**

Size	D	E	Weight
2 x 12	12	2 <sup>3</sup> / <sub>4</sub>	4.6
2 x 18	18	2 <sup>3</sup> / <sub>4</sub>	7.3
3 x 12	12	3	8.0
3 x 18	18	3	10.2
4 x 12	12	3 <sup>1</sup> / <sub>8</sub>	9.7

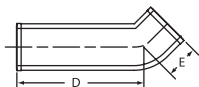

**PART NO. NH 14**

**Sixteenth Bend**

Size	D	Weight
1 <sup>1</sup> / <sub>2</sub>	2 <sup>1</sup> / <sub>8</sub>	1.2
2	2 <sup>1</sup> / <sub>8</sub>	1.4
3	2 <sup>1</sup> / <sub>4</sub>	2.1
4	2 <sup>5</sup> / <sub>16</sub>	3.4
5	2 <sup>7</sup> / <sub>8</sub>	5.4
6	3	6.7
8	3 <sup>3</sup> / <sub>4</sub>	12.0



**PART NO. NH 16**

**Short Sweep**

Size	D	Weight
2	6 <sup>1</sup> / <sub>2</sub>	3.1
3	7	6.3
4	7 <sup>1</sup> / <sub>2</sub>	8.1
5	8 <sup>1</sup> / <sub>2</sub>	13.1
6	9	17.1
8	10 <sup>1</sup> / <sub>2</sub>	31.0
10	12	53.4
12	13 <sup>1</sup> / <sub>4</sub>	61.3
15	14 <sup>3</sup> / <sub>4</sub>	105.6

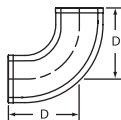

**PART NO. EZS 14**

**Extended Short Sweep**

Size	E	F	Weight
2 x 18	6½	18	8.0
2 x 24	6½	24	11.0
2 x 34	6½	34	13.9

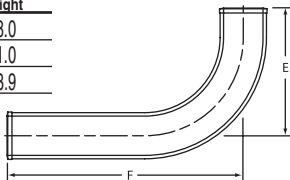

N O H B

**PART NO. NH 18**

**Long Sweep**

Size	D	Weight
1½	9¼	4.4
2	9½	5.8
3	10	9.4
4	10½	12.3
5	11½	18.6
6	12	23.3

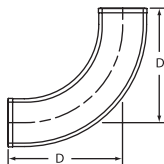

**PART NO. NH 18**

**Reducing Long Sweep**

Size	D	Weight
4 x 3	10½	12.4

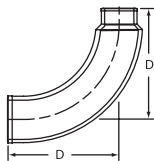

## PART NO. NH 20

Size	Wye			Weight
	D	F	G	
1½ x 1½	4	6	2	2.5
2 x 2	4 <sup>5</sup> / <sub>8</sub>	6 <sup>5</sup> / <sub>8</sub>	2	3.3
3 x 1½	4 <sup>5</sup> / <sub>8</sub>	6 <sup>1</sup> / <sub>8</sub>	1 <sup>15</sup> / <sub>16</sub>	4.4
3 x 2	5 <sup>5</sup> / <sub>16</sub>	6 <sup>5</sup> / <sub>8</sub>	1½	3.4
3	5¾	8	2¼	4.6
4 x 2	6	6 <sup>5</sup> / <sub>8</sub>	1	5.1
4 x 3	6½	8	1 <sup>11</sup> / <sub>16</sub>	7.3
4	7 <sup>1</sup> / <sub>16</sub>	9½	2 <sup>7</sup> / <sub>16</sub>	9.1
5 x 2	7½	8 <sup>1</sup> / <sub>16</sub>	1 <sup>15</sup> / <sub>16</sub>	8.8
5 x 3	8	9 <sup>11</sup> / <sub>16</sub>	1 <sup>11</sup> / <sub>16</sub>	10.5
5 x 4	8½	11 <sup>3</sup> / <sub>16</sub>	2 <sup>7</sup> / <sub>16</sub>	13.1
5	9½	12 <sup>5</sup> / <sub>8</sub>	3 <sup>1</sup> / <sub>8</sub>	15.1
6 x 2	8¼	8 <sup>5</sup> / <sub>16</sub>	½	9.8
6 x 3	8¾	9¾	1¼	12.5
6 x 4	9¼	11 <sup>3</sup> / <sub>16</sub>	1 <sup>15</sup> / <sub>16</sub>	14.6
6 x 5	10¼	12½	2 <sup>9</sup> / <sub>16</sub>	17.6
6	10¾	14 <sup>1</sup> / <sub>16</sub>	3 <sup>5</sup> / <sub>16</sub>	19.7
8 x 3	9 <sup>13</sup> / <sub>16</sub>	9 <sup>15</sup> / <sub>16</sub>	⅛	17.5
8 x 4	10 <sup>3</sup> / <sub>8</sub>	11 <sup>7</sup> / <sub>16</sub>	1 <sup>15</sup> / <sub>16</sub>	22.0
8 x 5	11 <sup>3</sup> / <sub>8</sub>	12 <sup>13</sup> / <sub>16</sub>	1 <sup>5</sup> / <sub>8</sub>	23.9
8 x 6	11 <sup>13</sup> / <sub>16</sub>	14 <sup>3</sup> / <sub>16</sub>	2 <sup>5</sup> / <sub>16</sub>	28.3
8	13 <sup>3</sup> / <sub>8</sub>	17 <sup>1</sup> / <sub>8</sub>	3¾	36.3
10 x 4	11 <sup>11</sup> / <sub>16</sub>	12 <sup>5</sup> / <sub>8</sub>	¾	32.9
10 x 6	13 <sup>1</sup> / <sub>8</sub>	15 <sup>7</sup> / <sub>16</sub>	2 <sup>3</sup> / <sub>16</sub>	42.1
10 x 8	14 <sup>11</sup> / <sub>16</sub>	18 <sup>3</sup> / <sub>8</sub>	3 <sup>5</sup> / <sub>8</sub>	56.1
10	16½	21½	5 <sup>1</sup> / <sub>16</sub>	74.9
12	19¾	25½	5¾	97.0
15	23¼	30	6¾	189.5

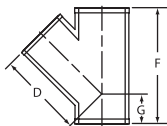

**PART NO. NH 21**

**Double Wye**

Size	D	F	Weight
2	4 <sup>5</sup> / <sub>8</sub>	6 <sup>5</sup> / <sub>8</sub>	4.5
3 x 2	5 <sup>5</sup> / <sub>16</sub>	6 <sup>5</sup> / <sub>8</sub>	5.5
3	5 <sup>3</sup> / <sub>4</sub>	8	7.9
4 x 2	6	6 <sup>5</sup> / <sub>8</sub>	6.5
4 x 3	6 <sup>1</sup> / <sub>2</sub>	8	8.8
4	7 <sup>1</sup> / <sub>16</sub>	9 <sup>1</sup> / <sub>2</sub>	12.1
5 x 4	8 <sup>1</sup> / <sub>2</sub>	11 <sup>3</sup> / <sub>16</sub>	15.7
6 x 4	9 <sup>1</sup> / <sub>4</sub>	11 <sup>3</sup> / <sub>16</sub>	16.4
6	10 <sup>3</sup> / <sub>4</sub>	14 <sup>1</sup> / <sub>16</sub>	27.4
8	13 <sup>3</sup> / <sub>8</sub>	17 <sup>1</sup> / <sub>8</sub>	45.3
8 x 4	10 <sup>3</sup> / <sub>8</sub>	11 <sup>7</sup> / <sub>16</sub>	23.0
8 x 6	11 <sup>13</sup> / <sub>16</sub>	14 <sup>3</sup> / <sub>16</sub>	31.3

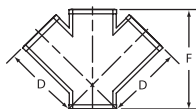

N  
O  
-  
H  
U  
B

**PART NO. NH 21A**

**Upright Wye**

Size	H	E	F	G	Weight
2	8 <sup>1</sup> / <sub>4</sub>	5 <sup>1</sup> / <sub>2</sub>	7	2	4.8
3 x 2	8 <sup>3</sup> / <sub>16</sub>	5 <sup>1</sup> / <sub>2</sub>	7	1 <sup>1</sup> / <sub>2</sub>	5.7
3	8 <sup>7</sup> / <sub>16</sub>	5 <sup>1</sup> / <sub>2</sub>	8 <sup>3</sup> / <sub>8</sub>	2 <sup>3</sup> / <sub>16</sub>	9.5
4 x 2	8 <sup>1</sup> / <sub>4</sub>	5 <sup>1</sup> / <sub>2</sub>	7	1	7.7
4 x 3	8 <sup>7</sup> / <sub>16</sub>	5 <sup>1</sup> / <sub>2</sub>	8 <sup>3</sup> / <sub>8</sub>	1 <sup>11</sup> / <sub>16</sub>	10.1
4	9 <sup>1</sup> / <sub>8</sub>	6	9 <sup>3</sup> / <sub>4</sub>	2 <sup>7</sup> / <sub>16</sub>	12.9
5 x 2	9	6 <sup>1</sup> / <sub>8</sub>	8	1	11.0
5	11 <sup>7</sup> / <sub>16</sub>	7 <sup>1</sup> / <sub>8</sub>	12 <sup>3</sup> / <sub>4</sub>	2 <sup>3</sup> / <sub>4</sub>	19.9

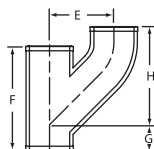

**PART NO. NH 22**

**Combination**

Size	D	E	F	Weight
1½	4¾	5¾	6	3.1
2 x 1½	5	5¾	6	3.4
2	5¾	6¼	6⅝	3.5
3 x 1½	5½	6¾	6⅝	5.0
3 x 2	5½	6¾	6⅝	5.7
3	7 <sup>5</sup> / <sub>16</sub>	8	8	8.5
4 x 2	5½	7¼	6⅝	6.6
4 x 3	7¼	8½	8	9.5
4	9¼	10	9½	13.7
5 x 2	5 <sup>15</sup> / <sub>16</sub>	7¾	8 <sup>1</sup> / <sub>16</sub>	8.5
5 x 3	7¾	9	9 <sup>11</sup> / <sub>16</sub>	12.0
5 x 4	9¾	10½	11 <sup>3</sup> / <sub>16</sub>	17.1
5	11¾	12½	12 <sup>5</sup> / <sub>8</sub>	19.7
6 x 2	6	8¼	8 <sup>5</sup> / <sub>16</sub>	12.0
6 x 3	7 <sup>13</sup> / <sub>16</sub>	9½	9¾	14.7
6 x 4	9¾	11	11 <sup>3</sup> / <sub>16</sub>	18.4
6 x 5	11 <sup>11</sup> / <sub>16</sub>	13	12½	23.4
6	13 <sup>5</sup> / <sub>8</sub>	14¾	14 <sup>1</sup> / <sub>16</sub>	30.0
8 x 4	9 <sup>7</sup> / <sub>16</sub>	11 <sup>5</sup> / <sub>16</sub>	11 <sup>3</sup> / <sub>16</sub>	25.1
8 x 6	12	13¾	13 <sup>15</sup> / <sub>16</sub>	35.4
8	14¾	15 <sup>9</sup> / <sub>16</sub>	16 <sup>15</sup> / <sub>16</sub>	49.3

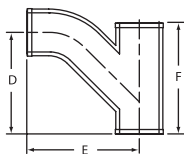

**PART NO. EZS 15**

**Extended Combination**

Size	E	F	G	Weight
2 x 24	6 <sup>3</sup> / <sub>16</sub>	25 <sup>3</sup> / <sub>8</sub>	24	12.0
2 x 36	6 <sup>3</sup> / <sub>16</sub>	36	34¾	15.4

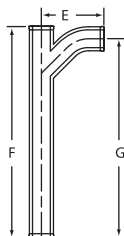

**PART NO. NH 24**

**Double Combination**

Size	D	E	F	Weight
2	5 <sup>3</sup> / <sub>8</sub>	6 <sup>1</sup> / <sub>8</sub>	6 <sup>5</sup> / <sub>8</sub>	6.3
3 x 2	5 <sup>1</sup> / <sub>2</sub>	6 <sup>3</sup> / <sub>4</sub>	6 <sup>5</sup> / <sub>8</sub>	7.7
3	7 <sup>5</sup> / <sub>16</sub>	8	8	11.8
4 x 2	5 <sup>1</sup> / <sub>2</sub>	7 <sup>1</sup> / <sub>4</sub>	6 <sup>5</sup> / <sub>8</sub>	8.3
4 x 3	7 <sup>1</sup> / <sub>4</sub>	8 <sup>1</sup> / <sub>2</sub>	8	13.7
4	9 <sup>1</sup> / <sub>4</sub>	10	9 <sup>1</sup> / <sub>2</sub>	20.5

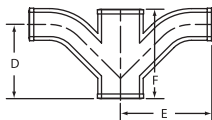

N  
O  
-  
H  
U  
B

**PART NO. NH 26**

**Tapped Wye**

Size	D	F	Weight
2 x 1 <sup>1</sup> / <sub>2</sub>	5 <sup>1</sup> / <sub>16</sub>	6 <sup>5</sup> / <sub>8</sub>	3.4
2 x 2	5 <sup>1</sup> / <sub>16</sub>	6 <sup>5</sup> / <sub>8</sub>	4.6
3 x 1 <sup>1</sup> / <sub>2</sub>	5 <sup>3</sup> / <sub>4</sub>	6 <sup>5</sup> / <sub>8</sub>	5.1
3 x 2	5 <sup>13</sup> / <sub>16</sub>	6 <sup>5</sup> / <sub>8</sub>	5.3
4 x 1 <sup>1</sup> / <sub>2</sub>	6 <sup>7</sup> / <sub>16</sub>	6 <sup>5</sup> / <sub>8</sub>	6.0
4 x 2	6 <sup>1</sup> / <sub>2</sub>	6 <sup>5</sup> / <sub>8</sub>	7.2

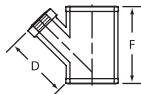

**PART NO. NH 27**

**Tapped Double Wye**

Size	D	F	Weight
2 x 1 <sup>1</sup> / <sub>2</sub>	5 <sup>1</sup> / <sub>16</sub>	6 <sup>5</sup> / <sub>8</sub>	5.6

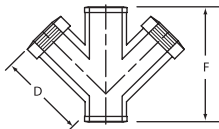

**PART NO. NH 28**

**Sanitary Tee**

Size	E	F	D	Weight
1½ x 1½	4¼	6½	4¼	2.9
2 x 1½	4½	6 <sup>5</sup> / <sub>8</sub>	4¼	3.4
2	4½	6 <sup>7</sup> / <sub>8</sub>	4½	3.1
3 x 1½	5	6½	4¼	4.5
3 x 2	5	6 <sup>7</sup> / <sub>8</sub>	4½	3.7
3	5	8	5	5.5
4 x 2	5½	6 <sup>7</sup> / <sub>8</sub>	4½	5.3
4 x 3	5½	8	5	7.6
4	5½	9 <sup>1</sup> / <sub>8</sub>	5½	8.5
5 x 2	6½	8½	5	8.3
5 x 3	6	9 <sup>5</sup> / <sub>16</sub>	5½	10.2
5 x 4	6	10 <sup>13</sup> / <sub>32</sub>	6	11.5
5	6½	11 <sup>7</sup> / <sub>16</sub>	6½	12.5
6 x 2	6½	8 <sup>3</sup> / <sub>16</sub>	5	9.9
6 x 3	6½	9 <sup>3</sup> / <sub>16</sub>	5½	11.5
6 x 4	6½	10 <sup>1</sup> / <sub>16</sub>	6	12.0
6 x 5	7	11½	6½	15.6
6	7	12½	7	12.9
8 x 3	7½	10 <sup>3</sup> / <sub>8</sub>	6	17.9
8 x 4	7½	11½	6½	21.6
8 x 5	8	12½	7	24.0
8 x 6	8	13½	7½	24.0
8	8½	15½	8½	30.8

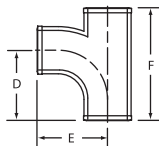

**PART NO. EZS 16**

**2" x 24" Two-Way Sanitary Tee**

Size	E	H	F	Weight
2 x 18	4½	4½	18	7.8
2 x 24	4½	4½	24	10.4

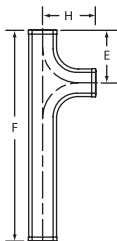

**PART NO. NH 30**

**Sanitary Cross**

Size	E	F	D	Weight
1½	4¼	6½	4½	3.6
2	4½	6⅞	4½	5.0
3x2	5	6⅞	4½	6.2
3	5	8	5	7.6
4x2	5½	6⅞	4½	7.3
4x3	5½	8	5	8.5
4	5½	9⅞	5½	11.0
5x4	6	10 <sup>13</sup> / <sub>32</sub>	6	13.4
6x4	6½	10 <sup>1</sup> / <sub>16</sub>	6	14.0
6	7	12½	7	21.0
8x4	7½	11½	6½	23.0
8	8½	15½	8½	37.9

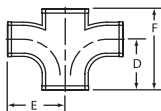

N O - H U B

**PART NO. NH 31**

**Sanitary Tee with 2" 90° Sanitary  
Opening Above Center  
(New Orleans Code)**

Size	C	D	E	F	G	Weight
3 (L)	4½	6	5	8½	5	6.7
3 (R)	4½	6	5	8½	5	6.3
4 (L)	5	6½	5½	9 <sup>3</sup> / <sub>16</sub>	5½	8.6
4 (R)	5	6½	5½	9 <sup>3</sup> / <sub>16</sub>	5½	8.5

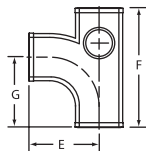
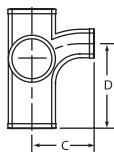

(Right Inlet)

**PART NO. NH 32**

**Sanitary Tee with 2" Side Inlets  
Right Hand and Left Hand**

Size	E	F	D	Weight
4 x 4 w/RH & LH	5 <sup>9</sup> / <sub>16</sub>	9⅞	5½	10.9

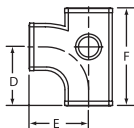

**PART NO. NH 32B**

**Sanitary Tee with 2" 45° Sanitary  
Opening Above Center  
(New Orleans Code)**

Size	D	E	F	G	Weight
3 (L)	6	5	8½	5	8.2
3 (R)	6	5	8½	5	7.8
3 (R&L)	6	5	8½	5	9.1
4 (L)	6½	5½	9¾	5½	9.6
4 (R)	6½	5½	9¾	5½	9.4

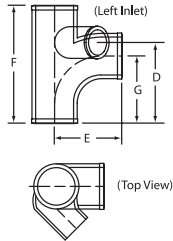

**PART NO. NH 33A**

**Sanitary Cross with 2" 90° Sanitary  
Openings Above Center  
(New Orleans Code)**

Size	C	D	E	F	G	Weight
4	5	6½	5½	9¾	5½	10.8

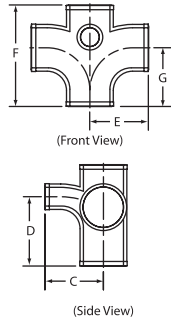

**PART NO. NH 33C**

**Sanitary Cross with Two 2" 90°  
Sanitary Openings Above Center  
(New Orleans Code)**

Size	C	D	E	F	G	Weight
3	4½	6	5	8½	5	9.0
4	5	6½	5½	9¾	5½	11.9

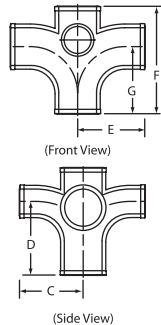

**PART NO. NH 33F**

**Sanitary Cross with Two 2" 45° Sanitary Openings Same Side (New Orleans Code)**

Size	D	E	F	G	Weight
3	6	5	8½	5	9.8
4	5½	5½	9½	5½	13.8

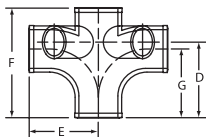

**PART NO. NH 33G**

**Sanitary Cross with 3" Vent and Two 2" 45° Inlets**

Size	A	B	C	F	G	Weight
4x3x4x2x2	3¾	5¼	4¾	10½	6½	24.0

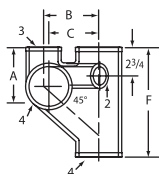
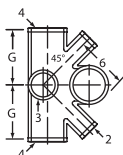

**PART NO. NH 34**

**Sanitary Tapped Tee**

Size	D	E	F	Weight
1½ x 1¼	3¼	2 <sup>9</sup> / <sub>16</sub>	5 <sup>11</sup> / <sub>16</sub>	2.3
1½ x 1½	3¼	2 <sup>9</sup> / <sub>16</sub>	5 <sup>11</sup> / <sub>16</sub>	2.5
2 x 1¼	3¼	2 <sup>13</sup> / <sub>16</sub>	5 <sup>11</sup> / <sub>16</sub>	2.8
2 x 1½	3¼	2 <sup>13</sup> / <sub>16</sub>	5 <sup>11</sup> / <sub>16</sub>	3.1
2 x 2	3¾	3 <sup>1</sup> / <sub>16</sub>	6 <sup>3</sup> / <sub>8</sub>	3.8
3 x 1¼	3¼	3 <sup>5</sup> / <sub>16</sub>	5 <sup>11</sup> / <sub>16</sub>	3.7
3 x 1½	3¼	3 <sup>5</sup> / <sub>16</sub>	5 <sup>11</sup> / <sub>16</sub>	3.6
3 x 2	3¾	3 <sup>9</sup> / <sub>16</sub>	6 <sup>3</sup> / <sub>8</sub>	4.9
3 x 3	4 <sup>7</sup> / <sub>8</sub>	4 <sup>1</sup> / <sub>8</sub>	8	7.3
4 x 1¼	3¼	3 <sup>13</sup> / <sub>16</sub>	5 <sup>11</sup> / <sub>16</sub>	4.0
4 x 1½	3¼	3¾	5 <sup>11</sup> / <sub>16</sub>	4.8
4 x 2	3¾	4 <sup>1</sup> / <sub>16</sub>	6 <sup>3</sup> / <sub>8</sub>	5.8
4 x 3	4½	4 <sup>3</sup> / <sub>8</sub>	8	8.4
5 x 1½	3¾	4 <sup>5</sup> / <sub>16</sub>	7 <sup>3</sup> / <sub>16</sub>	6.5
5 x 2	4¼	4 <sup>9</sup> / <sub>16</sub>	8	9.3
6 x 1½	3¾	4 <sup>13</sup> / <sub>16</sub>	6¾	8.4
6 x 2	4¼	5 <sup>1</sup> / <sub>16</sub>	7 <sup>7</sup> / <sub>16</sub>	9.2

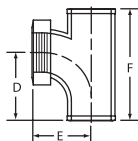

**PART NO. EZS 17**

**2" x 22<sup>7</sup>/<sub>8</sub>" Extended Tapped  
Sanitary Tee**

Size	H	F	Weight
2 x 1 <sup>1</sup> / <sub>2</sub> x 22 <sup>7</sup> / <sub>8</sub>	3 <sup>1</sup> / <sub>4</sub>	22 <sup>7</sup> / <sub>8</sub>	9.6
2 x 2 x 22 <sup>7</sup> / <sub>8</sub>	3 <sup>3</sup> / <sub>4</sub>	22 <sup>7</sup> / <sub>8</sub>	9.2

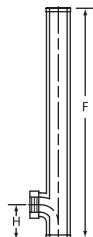

**PART NO. EZS 27**

**Sanitary Tapped Tee**

Size	H	F	Weight
2 x 1 <sup>1</sup> / <sub>2</sub> x 31	11 <sup>1</sup> / <sub>4</sub>	31	12.6
2 x 2 x 31	11 <sup>1</sup> / <sub>4</sub>	31	13.6

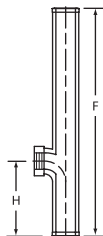

**PART NO. NH 35**

**Sanitary Tapped Cross**

Size	D	E	F	Weight
1 <sup>1</sup> / <sub>2</sub> x 1 <sup>1</sup> / <sub>2</sub>	3 <sup>1</sup> / <sub>4</sub>	2 <sup>9</sup> / <sub>16</sub>	5 <sup>11</sup> / <sub>16</sub>	3.4
2 x 1 <sup>1</sup> / <sub>4</sub>	3 <sup>1</sup> / <sub>4</sub>	2 <sup>13</sup> / <sub>16</sub>	5 <sup>11</sup> / <sub>16</sub>	3.9
2 x 1 <sup>1</sup> / <sub>2</sub>	3 <sup>1</sup> / <sub>4</sub>	2 <sup>13</sup> / <sub>16</sub>	5 <sup>11</sup> / <sub>16</sub>	4.0
2 x 2	3 <sup>3</sup> / <sub>4</sub>	3 <sup>1</sup> / <sub>16</sub>	6 <sup>3</sup> / <sub>8</sub>	5.3
3 x 1 <sup>1</sup> / <sub>2</sub>	3 <sup>1</sup> / <sub>4</sub>	3 <sup>5</sup> / <sub>16</sub>	5 <sup>11</sup> / <sub>16</sub>	4.3
3 x 2	3 <sup>3</sup> / <sub>4</sub>	3 <sup>9</sup> / <sub>16</sub>	6 <sup>3</sup> / <sub>8</sub>	6.1
4 x 1 <sup>1</sup> / <sub>2</sub>	3 <sup>1</sup> / <sub>4</sub>	3 <sup>3</sup> / <sub>4</sub>	5 <sup>11</sup> / <sub>16</sub>	5.5
4 x 2	3 <sup>3</sup> / <sub>4</sub>	4 <sup>1</sup> / <sub>16</sub>	6 <sup>3</sup> / <sub>8</sub>	6.9

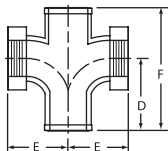

**PART NO. EZS 18**

**2" x 22<sup>7</sup>/<sub>8</sub>" Extended Tapped  
Sanitary Cross**

Size	H	F	Weight
2 x 1 <sup>1</sup> / <sub>2</sub> x 22 <sup>7</sup> / <sub>8</sub>	3 <sup>1</sup> / <sub>4</sub>	22 <sup>7</sup> / <sub>8</sub>	10.0
2 x 2 x 22 <sup>7</sup> / <sub>8</sub>	3 <sup>3</sup> / <sub>4</sub>	22 <sup>7</sup> / <sub>8</sub>	11.9

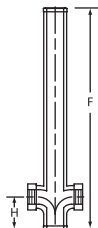

**PART NO. EZS 28**

**Sanitary Tapped Cross**

Size	H	F	Weight
2 x 1 <sup>1</sup> / <sub>2</sub> x 31	11 <sup>1</sup> / <sub>4</sub>	31	15.0
2 x 2 x 31	11 <sup>1</sup> / <sub>4</sub>	31	15.0

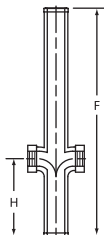

**PART NO. NH 35B**

**Double Vertical Sanitary  
Tapped Tee**

Size	E	F	G	H	Weight
2 x 1 <sup>1</sup> / <sub>2</sub>	2 <sup>13</sup> / <sub>16</sub>	9 <sup>3</sup> / <sub>4</sub>	4 <sup>1</sup> / <sub>2</sub>	3 <sup>1</sup> / <sub>4</sub>	4.8

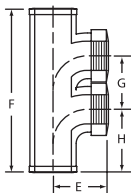

**PART NO. NH 36**

**Test Tee Less Plug**

**and PART NO. NH 36S**

**Test Tee with Southern  
Raised-Head Brass Plug Installed  
(2" through 8" only)**

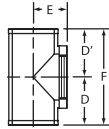

Size	IPS Tap	E	F	D	D'	Weight
2	2	2	6 <sup>3</sup> / <sub>8</sub>	3 <sup>3</sup> / <sub>16</sub>	3 <sup>3</sup> / <sub>16</sub>	3.0
3	3	2 <sup>11</sup> / <sub>16</sub>	7 <sup>3</sup> / <sub>4</sub>	3 <sup>7</sup> / <sub>8</sub>	3 <sup>7</sup> / <sub>8</sub>	5.8
4	4	3	8 <sup>7</sup> / <sub>8</sub>	4 <sup>7</sup> / <sub>16</sub>	4 <sup>7</sup> / <sub>16</sub>	9.2
5	5	4 <sup>1</sup> / <sub>2</sub>	11 <sup>1</sup> / <sub>2</sub>	5 <sup>3</sup> / <sub>4</sub>	5 <sup>3</sup> / <sub>4</sub>	15.2
6	6	5	12 <sup>1</sup> / <sub>2</sub>	6 <sup>1</sup> / <sub>4</sub>	6 <sup>1</sup> / <sub>4</sub>	22.0
8	8	6	15 <sup>1</sup> / <sub>4</sub>	7 <sup>5</sup> / <sub>8</sub>	7 <sup>5</sup> / <sub>8</sub>	37.1
10	10	6 <sup>1</sup> / <sub>2</sub>	20	10	10	59.7
4 x 3	3 <sup>1</sup> / <sub>2</sub>	2 <sup>7</sup> / <sub>8</sub>	9 <sup>1</sup> / <sub>2</sub>	5	4 <sup>1</sup> / <sub>2</sub>	8.0

**PART NO. NH 40**

**Increaser-Reducer**

Size	F	Weight
2 x 3	8	3.8
2 x 4	8	4.4
3 x 4	8	5.0

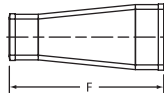

**PART NO. NH 40A**

**Short Reducer**

Size	F	Weight
2 x 1½	3⅝	1.1
3 x 1½	3⅝	1.8
3 x 2	3⅝	1.8
4 x 2	3⅝	2.3
4 x 3	3⅝	2.3
5 x 2	4	3.3
5 x 3	4	3.8
5 x 4	4	3.2
6 x 2	4	4.3
6 x 3	4	3.7
6 x 4	4	4.1
6 x 5	4½	4.3
8 x 2	4½	7.0
8 x 3	4½	7.6
8 x 4	4½	7.7
8 x 5	5	7.3
8 x 6	5	8.0
10 x 4	5½	12.5
10 x 6	6	13.3
10 x 8	6	14.9
12 x 4	6½	19.1
12 x 6	6½	18.3
12 x 8	7	17.3
12 x 10	7½	18.9
15 x 4	7	30.0
15 x 6	7	31.8
15 x 8	7	32.2
15 x 10	7½	32.2
15 x 12	7¾	30.5



**PART NO. NH 42**

**P-Trap**

Size	D	J	Weight
1½	6¾	3½	3.4
2	7½	4	4.7
3	9	5½	8.9
4	10½	6½	17.0
6	14	8½	33.6

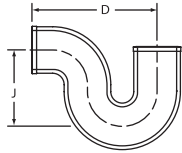

**PART NO. NH 42**

**Long P-Trap**

Size	D	J	Weight
2 x 12	12	4	6.1
2 x 18	18	4	8.0

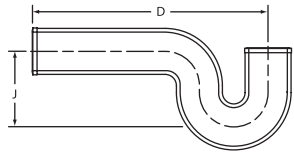

**PART NO. NH 42A**

**P-Trap, Reducing**

Size	D	J	Weight
3 x 2	9	5½	10.0

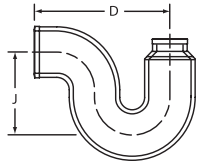

**PART NO. NH 43**

**P Trap with ½" Tap in Heel**

Size	C	D	E	J	Weight
2	4	7½	2	4	4.7
3	5	9	2	5½	10.8
4	6	10½	2	6½	18.8

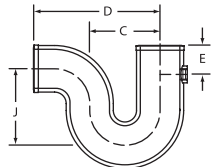

**PART NO. EZS 9**

**P-Trap with 1 1/2" Tapped Side Inlet**

Size	H	F	Weight
2	5 3/16	7 1/2	6.2

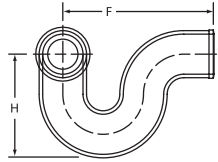

(Illustration Shows Right Hand)

**PART NO. EZS 10**

**P-Trap with 2" Side Inlet**

Size	C	D	J	Weight
2	1 3/16	7 1/2	3 1/16	6.4

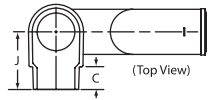

(Top View)

(Side View)

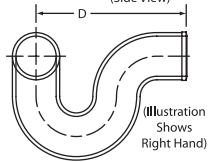

(Illustration Shows Right Hand)

**PART NO. NH 44**

**P-Trap with Tapped Inlet**

Size	C	D	J	Weight
1 1/2 x 1 1/2	3 1/2	6 3/4	3 1/2	3.0
2 x 1 1/2	4	7 1/2	4	4.5
2 x 2	4	7 1/2	4	5.4

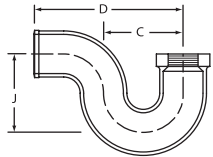

**PART NO. NH 44A**

**Deep Seal P Trap**

Size	C	D	J	Weight
2	4	7 1/2	7	6.6
3	5	9	7	11.0
4	6	10 1/2	8	18.6

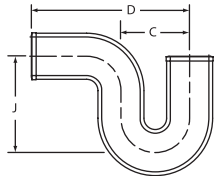

**PART NO. NH 45**

**Running Trap with Vent**

Size	D	E	F	G	Weight
4	6½	4½	15	10½	20.5

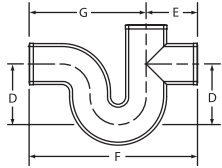

**PART NO. NH 45A**

**Running Trap with Double Vent**

Size	C	D	E	F	G	Weight
4	6	6½	4½	15	10½	21.4

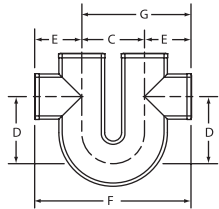

**PART NO. EZS 13**

**45° Vented Tub Wye**

Size	E	F	G	Weight
2	12	5¼	15¾	10.1

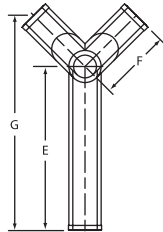

**PART NO. EZS 38**

**Vented Tub Wye**

Size	G	H	F	Weight
2	9½	5¼	15	9.4
2	24	5¼	29½	13.7

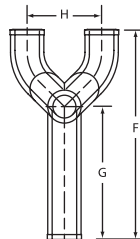

**PART NO. EZS 38 L**

**Vented Tub Wye  
Left Hand**

Size	G	H	F	Weight
2	9 <sup>1</sup> / <sub>2</sub>	3 <sup>3</sup> / <sub>4</sub>	15	10.0

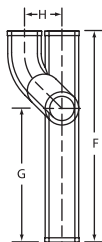

**PART NO. EZS 38 R**

**Vented Tub Wye  
Right Hand**

Size	G	H	F	Weight
2	9 <sup>1</sup> / <sub>2</sub>	3 <sup>3</sup> / <sub>4</sub>	15	9.0

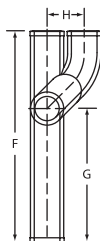

**PART NO. NH 48**

**Tapped Adapters**

Size	F	IPS Tapping	Weight
1 <sup>1</sup> / <sub>2</sub> x 1 <sup>1</sup> / <sub>2</sub>	2 <sup>5</sup> / <sub>8</sub>	1 <sup>1</sup> / <sub>2</sub>	1.3
2 x 1 <sup>1</sup> / <sub>4</sub>	2 <sup>3</sup> / <sub>16</sub>	1 <sup>1</sup> / <sub>4</sub>	1.0
2 x 1 <sup>1</sup> / <sub>2</sub>	2 <sup>3</sup> / <sub>16</sub>	1 <sup>1</sup> / <sub>2</sub>	0.9
2 x 2	2 <sup>5</sup> / <sub>8</sub>	2	1.7
3 x 2	2 <sup>3</sup> / <sub>16</sub>	2	1.0

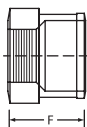

**PART NO. NH 50**

**Blind Plug**

Size	F	Weight
1½	1¾	0.6
2	1¾	0.7
3	1¾	1.1
4	1¾	2.0
5	1¾	2.9
6	1¾	3.2
8	2¼	6.5
10	3	14.7
12	3½	17.6
15	3½	28.0

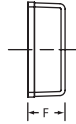

**PART NO. NH 52**

**Tapped Ferrule Less Brass Plug  
and PART NO. NH 52S**

**Tapped Ferrule with Southern  
Raised-Head Brass Plug Installed**

Size	F	IPS	
		Tapping	Weight
2	2 <sup>3</sup> / <sub>16</sub>	1½	0.9
3	2 <sup>3</sup> / <sub>16</sub>	2½	1.9
4	2 <sup>3</sup> / <sub>16</sub>	3½	2.5
5	4½	4	6.5
6	4½	5	8.0
8	4½	6	12.1

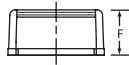

**PART NO. NH 53**

**Single Two-Way Cleanout**

Size	E	F	Weight
4	7½	15	16.0

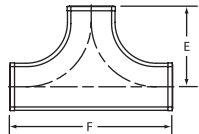

**PART NO. NH 53A**

**Two-Way Cleanout**

Size	D	E	F	G	Weight
4	8¼	2¾	12	6½	15.0

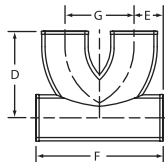

**PART NO. NH 54**

**Two-Way Baffle Cleanout**

Size	D	F	Weight
3 x 3 x 4	15	9	14.2
4 x 4 x 4	18 <sup>3</sup> / <sub>8</sub>	9 <sup>1</sup> / <sub>2</sub>	22.0

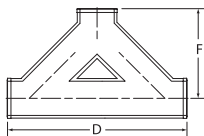

**PART NO. NH 56**

**Notched and Slotted Closet Collar**

Size	D	E	F	A	Weight
4 x 3	3 <sup>1</sup> / <sub>2</sub>	3 <sup>3</sup> / <sub>8</sub>	7 <sup>1</sup> / <sub>4</sub>	4 <sup>7</sup> / <sub>32</sub>	3.3
4 x 3	8	3 <sup>27</sup> / <sub>64</sub>	7 <sup>1</sup> / <sub>4</sub>	4	6.1
4 x 4	4	4 <sup>3</sup> / <sub>8</sub>	7 <sup>1</sup> / <sub>4</sub>	4 <sup>9</sup> / <sub>64</sub>	4.7
4 x 4	8	4 <sup>3</sup> / <sub>8</sub>	7 <sup>1</sup> / <sub>4</sub>	4 <sup>7</sup> / <sub>32</sub>	7.0

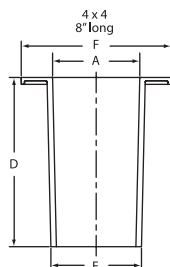
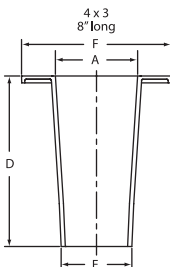
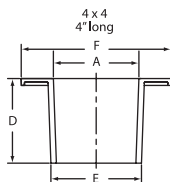
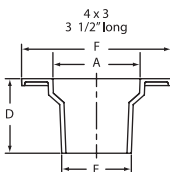

**PART NO. NH 57**

**Horizontal Twin Tapped Tee**

Size	A	D	F	H	Weight
3 x 1 <sup>1</sup> / <sub>2</sub>	1 <sup>3</sup> / <sub>8</sub>	4	7	3	7.3
4 x 1 <sup>1</sup> / <sub>2</sub>	1 <sup>3</sup> / <sub>8</sub>	4	7	3	8.0

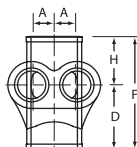

N O - H U B

**PART NO. NH 457**

**Vented Closet Tee  
with 2" Top Vent**

(Left or Right; Designed for use below the floor;  
Fitting does not require a baffle)

Size	B	C	D	E	F	G	Wt.
4x4x2x4(L)	4 <sup>1</sup> / <sub>4</sub>	5 <sup>1</sup> / <sub>4</sub>	3 <sup>3</sup> / <sub>4</sub>	4	10 <sup>1</sup> / <sub>2</sub>	3 <sup>3</sup> / <sub>4</sub>	12.1
4x4x2x4(R)	4 <sup>1</sup> / <sub>4</sub>	5 <sup>1</sup> / <sub>4</sub>	3 <sup>3</sup> / <sub>4</sub>	4	10 <sup>1</sup> / <sub>2</sub>	3 <sup>3</sup> / <sub>4</sub>	11.6

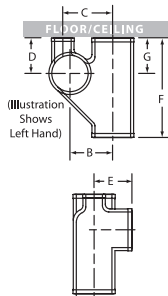

**PART NO. NH 458<sup>‡</sup>**

**Vented Closet Tee**

**with 2" Top Vent and 2" Side Opening**

(Left or Right; Designed for use below the floor;  
Fitting does not require a baffle)

Size	A	B	C	D	E	F	G	Wt.
4x4x2x2x4(L)	8 <sup>1</sup> / <sub>8</sub>	4 <sup>1</sup> / <sub>4</sub>	5 <sup>1</sup> / <sub>4</sub>	7 <sup>1</sup> / <sub>2</sub>	4	10 <sup>1</sup> / <sub>2</sub>	3 <sup>3</sup> / <sub>4</sub>	12.3
4x4x2x2x4(R)	8 <sup>1</sup> / <sub>8</sub>	4 <sup>1</sup> / <sub>4</sub>	5 <sup>1</sup> / <sub>4</sub>	7 <sup>1</sup> / <sub>2</sub>	4	10 <sup>1</sup> / <sub>2</sub>	3 <sup>3</sup> / <sub>4</sub>	12.2

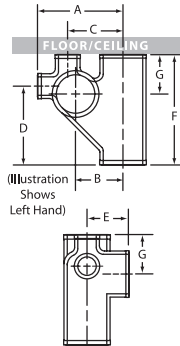

**PART NO. NH 463**

**Vented Closet Cross with 2" Top Vent**

(Designed for use below the floor;  
Fitting has a baffle)

Size	B	C	D	E	F	G	Wt.
4x4x2x4x4	4 <sup>1</sup> / <sub>4</sub>	5 <sup>1</sup> / <sub>4</sub>	3 <sup>3</sup> / <sub>4</sub>	4	10 <sup>1</sup> / <sub>2</sub>	3 <sup>3</sup> / <sub>4</sub>	15.0

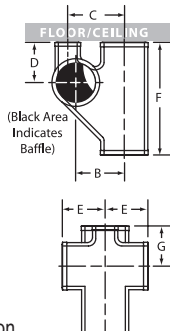

<sup>‡</sup> Additional drawing available in Detail Drawing Section

**PART NO. NH 464**

**Vented Closet Cross with 2" Top Vent  
and 2" Side Opening**  
(Designed for use below the floor;  
Fitting has a baffle)

Size	A	B	C	D	E	F	G	Wt.
4x4x2x2x4x4	8 1/8	4 1/4	5 1/4	7 1/2	4	10 1/2	3 3/4	15.6

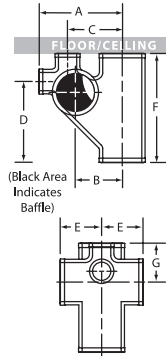

**PART NO. NH 502†**

**4" No Hub Prison Fitting with 2" Top Vent**  
(Designed for use above the floor; Baffle helps prevent  
passage of contraband between cells)

Part No.	Size	UPC# 611942-	A	C	F	G	Weight
NH 502	4 Less Tap	00639	8	5 1/4	12	8	20.3
NH 502	4 With Tap	00640	8	5 1/4	12	8	20.8
NH 502	4x3 Less Tap	11119	8	5 1/4	12	8	23.4
NH 502	4x3 With Tap	11120	8	5 1/4	12	8	23.4

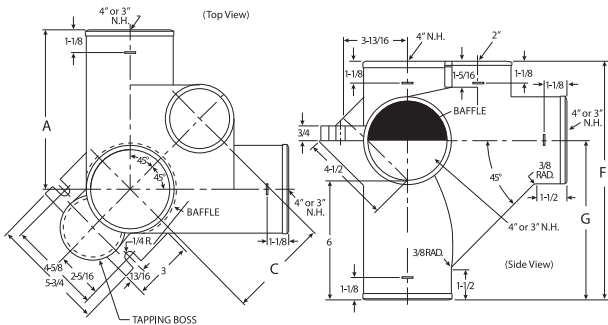

† Additional drawing available in Detail Drawing Section

**PART NO. EZS 50\***

**10'' Closet Fittings with 2'' Inlet**  
**(Double, Left Hand or Right Hand; Designed for use below the floor;**  
**Fitting does not have a baffle)**

Part No.	Size	UPC# 611942-	A	B	C	D	F	Weight
EZS 50D***	4	04484	10 <sup>3</sup> / <sub>4</sub>	6 <sup>1</sup> / <sub>2</sub>	3 <sup>3</sup> / <sub>4</sub>	4	4 <sup>1</sup> / <sub>2</sub>	15.0
EZS 50L	4	04476	10 <sup>3</sup> / <sub>4</sub>	6 <sup>1</sup> / <sub>2</sub>	3 <sup>3</sup> / <sub>4</sub>	4	4 <sup>1</sup> / <sub>2</sub>	12.3
EZS 50R	4	04477	10 <sup>3</sup> / <sub>4</sub>	6 <sup>1</sup> / <sub>2</sub>	3 <sup>3</sup> / <sub>4</sub>	4	4 <sup>1</sup> / <sub>2</sub>	12.2

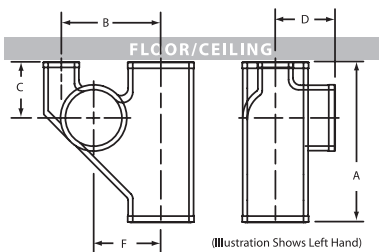

**PART NO. EZS 51\***

**10'' Closet Fittings with 2'' Inlet and 2'' Side Inlet**  
**(Double, Left Hand or Right Hand; Designed for use below the floor;**  
**Fitting does not have a baffle)**

Part No.	Size	UPC# 611942-	A	B	C	D	E	F	Weight
EZS 51D***	4	04424	10 <sup>3</sup> / <sub>4</sub>	6 <sup>1</sup> / <sub>2</sub>	3	4	9 <sup>1</sup> / <sub>2</sub>	4 <sup>1</sup> / <sub>2</sub>	15.0
EZS 51L	4	04425	10 <sup>3</sup> / <sub>4</sub>	6 <sup>1</sup> / <sub>2</sub>	3	4	9 <sup>1</sup> / <sub>2</sub>	4 <sup>1</sup> / <sub>2</sub>	12.8
EZS 51R	4	04473	10 <sup>3</sup> / <sub>4</sub>	6 <sup>1</sup> / <sub>2</sub>	3	4	9 <sup>1</sup> / <sub>2</sub>	4 <sup>1</sup> / <sub>2</sub>	12.6

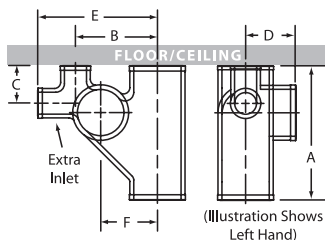

\* When ordering please specify Double, Left or Right.

\*\*\* Double closet fitting does not have a baffle.

## HOW TO DETERMINE RIGHT or LEFT HAND CROSS-OVER



With the vented end toward you, hold the fitting so that you are looking into its length with the curved side up. If the vent is on your left side, it is a Left Hand fitting. If the vent is on your right side, it is a Right Hand fitting.

### RIGHT HAND CROSS-OVER ILLUSTRATED

**Note: VENT CROSS-OVER**  
for use with EZS-50 through 800 Series fittings.  
Specify Right, Left, Plain or Double.

**Note: Our crossovers are designed for use with EZS starter fittings, that is for the vent and stack centerline to be 6½"**

## PART NO. EZS 7

### 2" Vent Cross-Over, Plain (No Outlets)

U.P.C. No.	Size	A	C	F	Weight
04429	2 x 18 <sup>3</sup> / <sub>8</sub>	4 <sup>7</sup> / <sub>8</sub>	9 <sup>3</sup> / <sub>16</sub>	18 <sup>3</sup> / <sub>8</sub>	8.1

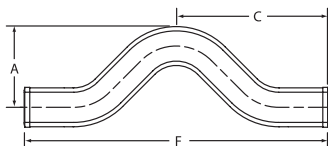

## PART NO. EZS 7D

### 2" Vent Cross-Over, Double (2 Inlets)

U.P.C. No.	Size	A	B	C	F	Weight
04430	2 x 18 <sup>3</sup> / <sub>8</sub>	4 <sup>7</sup> / <sub>8</sub>	6 <sup>1</sup> / <sub>2</sub>	9 <sup>3</sup> / <sub>16</sub>	18 <sup>3</sup> / <sub>8</sub>	8.0

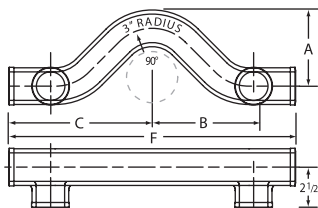

**PART NO. EZS 7L**

**2" Vent Cross-Over  
with Left Hand Inlet**

U.P.C. No.	Size	A	B	C	F	Weight
611942	2 x 18 <sup>3</sup> / <sub>8</sub>	4 <sup>7</sup> / <sub>8</sub>	6 <sup>1</sup> / <sub>2</sub>	9 <sup>3</sup> / <sub>16</sub>	18 <sup>3</sup> / <sub>8</sub>	8.2

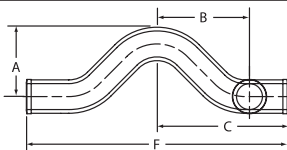

**PART NO. EZS 7R**

**2" Vent Cross-Over  
with Right Hand Inlet**

U.P.C. No.	Size	A	B	C	F	Weight
611942	2 x 18 <sup>3</sup> / <sub>8</sub>	4 <sup>7</sup> / <sub>8</sub>	6 <sup>1</sup> / <sub>2</sub>	9 <sup>3</sup> / <sub>16</sub>	18 <sup>3</sup> / <sub>8</sub>	8.4

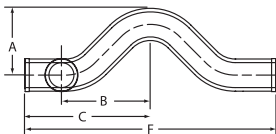

**PART NO. EZS 1**

**Figure One**

Size	E	F	D	Weight
2 x 1 <sup>1</sup> / <sub>2</sub>	3 <sup>3</sup> / <sub>16</sub>	7	4 <sup>7</sup> / <sub>8</sub>	5.3

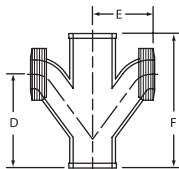

**PART NO. NH 25**

**Figure Five Double Fixture Fitting**

Size	D	E	F	G	Weight
2	6 <sup>1</sup> / <sub>2</sub>	5	8	1 <sup>3</sup> / <sub>16</sub>	7.0
3	8 <sup>7</sup> / <sub>8</sub>	6 <sup>9</sup> / <sub>16</sub>	10 <sup>1</sup> / <sub>8</sub>	2	10.5
3 x 2 x 3 x 3	8 <sup>7</sup> / <sub>8</sub>	6 <sup>9</sup> / <sub>16</sub>	9 <sup>1</sup> / <sub>4</sub>	2	10.7
4	10 <sup>1</sup> / <sub>4</sub>	7 <sup>3</sup> / <sub>4</sub>	12	1 <sup>5</sup> / <sub>16</sub>	22.5
4 x 2 x 4 x 4	10 <sup>1</sup> / <sub>4</sub>	7 <sup>3</sup> / <sub>4</sub>	11 <sup>1</sup> / <sub>2</sub>	1 <sup>5</sup> / <sub>16</sub>	19.8

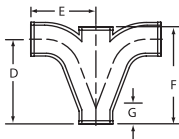

**PART NO. EZS 6\***

**Figure Six**

**(Double, Left Hand or Right Hand; Designed for use below the floor)**

Part No.	Size	C	D	E	F	H	Weight
EZS 6D**	3x2	4 <sup>1</sup> / <sub>8</sub>	7 <sup>9</sup> / <sub>16</sub>	5 <sup>1</sup> / <sub>16</sub>	11	3 <sup>7</sup> / <sub>16</sub>	13.0
EZS 6D**	4x2	4 <sup>1</sup> / <sub>2</sub>	9	6 <sup>1</sup> / <sub>2</sub>	13	4	23.1
EZS 6L	3x2	4 <sup>1</sup> / <sub>8</sub>	7 <sup>9</sup> / <sub>16</sub>	5 <sup>1</sup> / <sub>16</sub>	11	3 <sup>7</sup> / <sub>16</sub>	11.4
EZS 6L	4x2	4 <sup>1</sup> / <sub>2</sub>	9	6 <sup>1</sup> / <sub>2</sub>	13	4	18.0
EZS 6R	3x2	4 <sup>1</sup> / <sub>8</sub>	7 <sup>9</sup> / <sub>16</sub>	5 <sup>1</sup> / <sub>16</sub>	11	3 <sup>7</sup> / <sub>16</sub>	11.4
EZS 6R	4x2	4 <sup>1</sup> / <sub>2</sub>	9	6 <sup>1</sup> / <sub>2</sub>	13	4	18.0

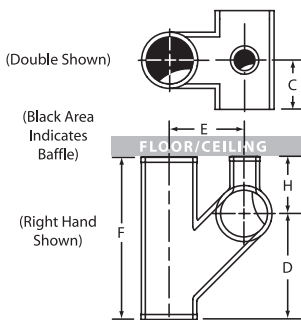

\* When ordering please specify Double, Left or Right.

\*\* Double fitting has a baffle.

**PART NO. EZS 8\***

**Figure Eight**

**(Double, Left Hand or Right Hand; Designed for use below the floor)**

Part No.	Size	C	D	E	F	H	Weight
EZS 8D**	3x2	4 <sup>1</sup> / <sub>8</sub>	7 <sup>9</sup> / <sub>16</sub>	5 <sup>1</sup> / <sub>16</sub>	11	3 <sup>7</sup> / <sub>16</sub>	13.0
EZS 8L	3x2	4 <sup>1</sup> / <sub>8</sub>	7 <sup>9</sup> / <sub>16</sub>	5 <sup>1</sup> / <sub>16</sub>	11	3 <sup>7</sup> / <sub>16</sub>	12.5
EZS 8L	4x2	4 <sup>1</sup> / <sub>2</sub>	9	6 <sup>1</sup> / <sub>2</sub>	13	4	19.8
EZS 8R	3x2	4 <sup>1</sup> / <sub>8</sub>	7 <sup>9</sup> / <sub>16</sub>	5 <sup>1</sup> / <sub>16</sub>	11	3 <sup>7</sup> / <sub>16</sub>	12.5
EZS 8R	4x2	4 <sup>1</sup> / <sub>2</sub>	9	6 <sup>1</sup> / <sub>2</sub>	13	4	19.8

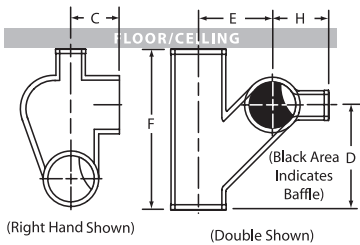

**PART NO. EZS 8A**

**Figure Eight Double Fixture Fitting, Extended\*\***

**(Designed for Use Below the Floor)**

Size	D	E	F	H	Weight
4 x 2	9	6 <sup>1</sup> / <sub>2</sub>	13	8	23.4

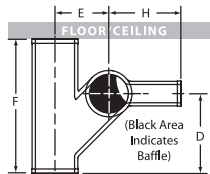

\* When ordering please specify Double, Left or Right.

\*\* Double fitting has a baffle.

**PART NO. EZS 100\***

**16" Closet Fittings with 2" Inlets**

(Double, Left Hand or Right Hand; Designed for use below the floor)

Part No.	Size	A	B	C	D	E	M	Weight
EZS 100D	4x16	16 <sup>3</sup> / <sub>4</sub>	5	4 <sup>1</sup> / <sub>2</sub>	6 <sup>1</sup> / <sub>2</sub>	5 <sup>1</sup> / <sub>2</sub>	5	22.0
EZS 100L	4x16	16 <sup>3</sup> / <sub>4</sub>	5	4 <sup>1</sup> / <sub>2</sub>	6 <sup>1</sup> / <sub>2</sub>	5 <sup>1</sup> / <sub>2</sub>	5	20.0
EZS 100R	4x16	16 <sup>3</sup> / <sub>4</sub>	5	4 <sup>1</sup> / <sub>2</sub>	6 <sup>1</sup> / <sub>2</sub>	5 <sup>1</sup> / <sub>2</sub>	5	21.1

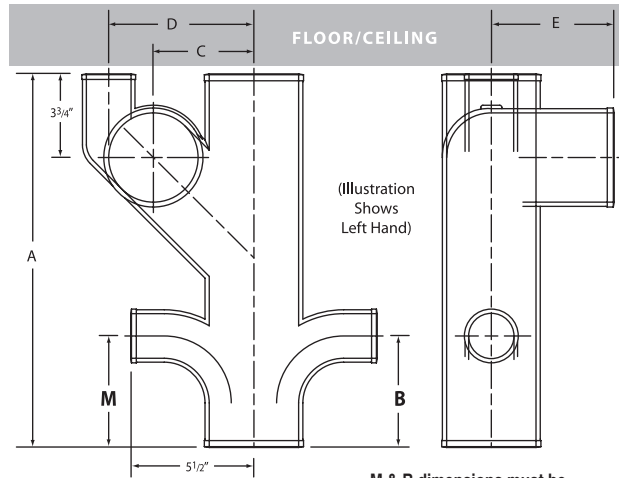

(Illustration Shows Left Hand)

**M & B dimensions must be measured from the bottom of the fitting.**

\* When ordering please specify Double, Left or Right.

**PART NO. EZS 400\*†**

**30'' Closet Fittings with 2'' Inlet**  
**(Double, Left Hand or Right Hand; Designed for use in the floor)**

Part No.	Size	A	B	C	D	E	M	Weight
EZS 400D	4x30	30	See Chart	4½	6½	5½	See Chart	38.9
EZS 400L	4x30	30	See Chart	4½	6½	5½	See Chart	36.8
EZS 400R	4x30	30	See Chart	4½	6½	5½	See Chart	35.4

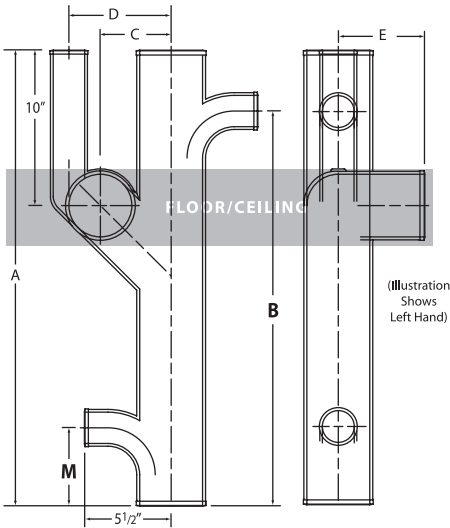

M & B dimensions must be measured from the bottom of the fitting.

M	B
12	26½
6½	
4	12
0	6½
	0

\* When ordering please specify Double, Left or Right.

† Additional drawing available in Detail Drawing Section

**PART NO. EZS 700\*\*†**

**Threaded Starter Fitting with or without No-Hub Inlets**  
(Double, Left Hand or Right Hand; Designed for use above the floor with back-outlet water closets; Double Starter fittings have a baffle)

Part No.	Size	A	B	C	D	E	Weight
EZS 700D**	4x28	0	0	5½	28	6½	40.0
EZS 700D**	4x28	0	8½	5½	28	6½	42.0
EZS 700D**	4x28	23½	8½	5½	28	6½	42.0
EZS 700L	4x28	0	0	5½	28	6½	34.6
EZS 700L	4x28	0	8½	5½	28	6½	35.7
EZS 700L	4x28	14	8½	5½	28	6½	36.3
EZS 700L	4x28	23½	8½	5½	28	6½	32.0
EZS 700R	4x28	0	0	5½	28	6½	30.0
EZS 700R	4x28	0	8½	5½	28	6½	34.0
EZS 700R	4x28	14	8½	5½	28	6½	35.3
EZS 700R	4x28	23½	8½	5½	28	6½	32.0

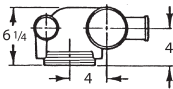

(Illustration Shows Left Hand)

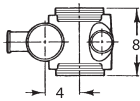

(Illustration Shows Double)

**A & B Dimensions must be measured from the top of the fitting.**

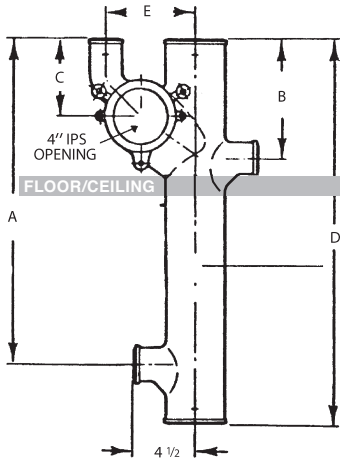

\* When ordering please specify Double, Left or Right.

2" inlets available

\*\* Double starter fittings have a baffle.

Note: Trim package not included in price of fitting

“0” dimension denotes the absence of the designated inlet.

† Additional drawing available in Detail Drawing Section

**PART NO. EZS 800\*†**

**Threaded Starter Fitting with or without No-Hub Inlets**  
**(Double, Left Hand or Right Hand; Designed for use above the floor with**  
**back-outlet water closets; Double starter fittings have a baffle)**

Part No.	Size	A	B	C	D	E	Weight
EZS 800D**	4x28	16	0	5½	28	6½	42.0
EZS 800D**	4x28	16	8½	5½	28	6½	42.0
EZS 800L	4x28	16	0	5½	28	6½	35.4
EZS 800L	4x28	16	8½	5½	28	6½	36.3
EZS 800R	4x28	16	0	5½	28	6½	35.6
EZS 800R	4x28	16	8½	5½	28	6½	35.3

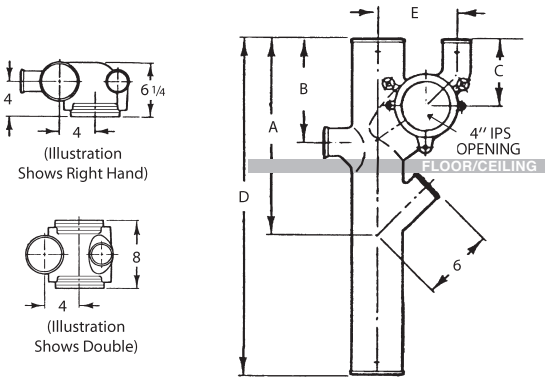

(Illustration Shows Right Hand)

(Illustration Shows Double)

2" inlets available

**A & B Dimensions must be measured from the top of the fitting.**

\* When ordering please specify Double, Left or Right.

\*\* Double starter fittings have a baffle.

Note: Trim package not included in price of fitting

“O” dimension denotes the absence of the designated inlet.

† Additional drawing available in Detail Drawing Section

**PART NO. EZS 710\***

**No-Hub Starter Fitting with or without 2" No-Hub Inlets**  
(Double, Left Hand or Right Hand; Designed for use above the floor with back-outlet water closets; Double starter fittings have a baffle)

Part No.	Size	A	B	C	D	E	Weight
EZS 710D**	4x28	0	0	5 1/2	28	4	43.0
EZS 710D**	4x28	0	8 1/2	5 1/2	28	4	43.0
EZS 710D**	4x28	23 1/2	8 1/2	5 1/2	28	4	43.0
EZS 710L	4x28	0	0	5 1/2	28	4	36.6
EZS 710L	4x28	0	8 1/2	5 1/2	28	4	36.6
EZS 710L	4x28	14	8 1/2	5 1/2	28	4	36.6
EZS 710L	4x28	23 1/2	8 1/2	5 1/2	28	4	36.6
EZS 710R	4x28	0	0	5 1/2	28	4	36.6
EZS 710R	4x28	0	8 1/2	5 1/2	28	4	36.6
EZS 710R	4x28	14	8 1/2	5 1/2	28	4	36.6
EZS 710R	4x28	23 1/2	8 1/2	5 1/2	28	4	36.6

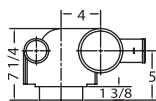

(Illustration Shows Left Hand)

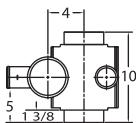

(Illustration Shows Double)

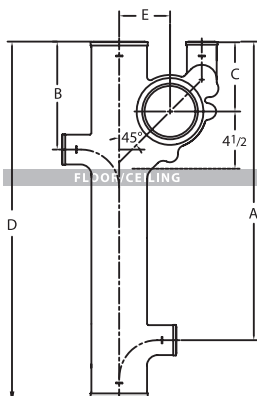

2" inlets available

**A & B Dimensions must be measured from the top of the fitting.**

\* When ordering please specify Double, Left or Right.

\*\* Double starter fittings have a baffle.

Note: Not designed for use with trim package

“0” dimension denotes the absence of the designated inlet.

**PART NO. EZS 810\***

**No-Hub Starter Fitting with or without 2" No-Hub Inlets**  
(Double, Left Hand or Right Hand; Designed for use above the floor with back-outlet water closets; Double starter fittings have a baffle)

Part No.	Size	A	B	C	D	E	Weight
EZS 810D**	4x28	16	0	5 1/2	28	6 1/2	43.0
EZS 810D**	4x28	16	8 1/2	5 1/2	28	6 1/2	43.0
EZS 810L	4x28	16	0	5 1/2	28	6 1/2	36.6
EZS 810L	4x28	16	8 1/2	5 1/2	28	6 1/2	36.6
EZS 810R	4x28	16	0	5 1/2	28	6 1/2	36.6
EZS 810R	4x28	16	8 1/2	5 1/2	28	6 1/2	36.6

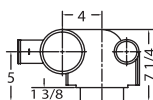

(Illustration Shows Right Hand)

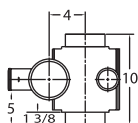

(Illustration Shows Double)

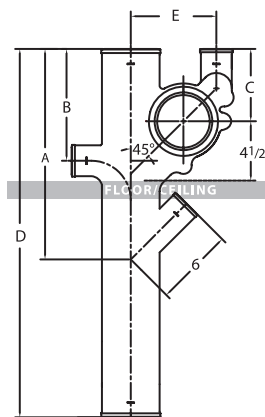

2" inlets available

**A & B Dimensions must be measured from the top of the fitting.**

\* When ordering please specify Double, Left or Right.

\*\* Double starter fittings have a baffle.

Note: Not designed for use with trim package

“0” dimension denotes the absence of the designated inlet.

**MOUNTING HARDWARE**

**PART NO. EZS 22**  
**Trim Package, Support Frame Assembly**

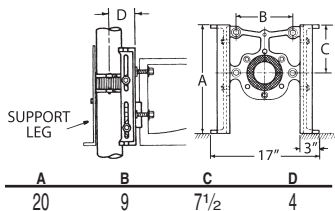

- 1—FRAME
- 1—LEFT LEG
- 1—RIGHT LEG
- 1—SUPPORT LEG (used for single only)
- 5—1/2" x 1 1/4" BOLTS
- 5—1/2" FLAT WASHERS

**PART NO. EZS 23**  
**Trim Package, Floor-Mounted Back-Outlet Assembly**  
(Note: Not to be used with PART NO. EZS 22 Support Frame Assembly)

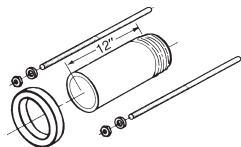

- 1—4" PVC Sch. 80 NIPPLE with TEST CAP
- 1—BOWL GASKET
- 2—5/16" x 12" RODS
- 2—5/16" HEX NUTS
- 2—5/16" FLAT WASHERS
- 2—5/16" CAP NUTS

**PART NO. EZS 24**  
**Trim Package, Wall-Hung Back-Outlet Assembly**

(Note: To be used with PART NO. EZS 22 Support Frame Assembly)

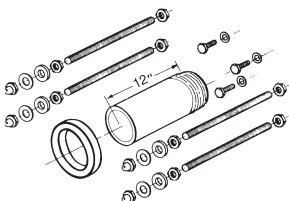

- 1—4" PVC Sch. 80 NIPPLE with TEST CAP
- 1—BOWL GASKET
- 4—5/8" x 12" RODS
- 4—5/8" CHROME CAP NUTS
- 8—5/8" JAM NUTS
- 4—5/8" FLAT WASHERS
- 4—5/8" FIBER WASHERS
- 3—3/8" x 1 1/2" BOLTS FOR FACEPLATE
- 3—3/8" FLAT WASHERS
- 4—5/8" STAR WASHERS

**Exploded View of Support Assembly Hardware**

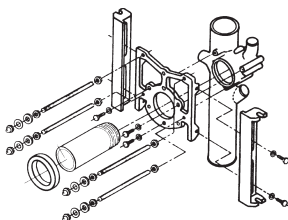

**EZS 22 and EZS 24 Assemblies Illustrated**

**TYPICAL HIGH-RISE BUILDING INSTALLATION**

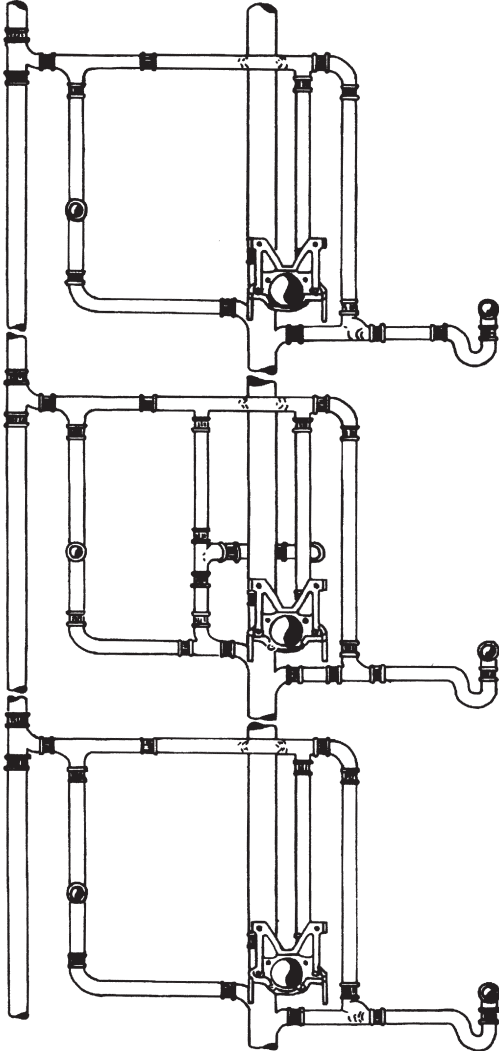

### TYPICAL BACK-TO-BACK INSTALLATION

Typical installation shows back-to-back water closets and back-outlet tubs. This system can be changed to use floor-mounted back-outlet water closets and bottom-outlet tubs.

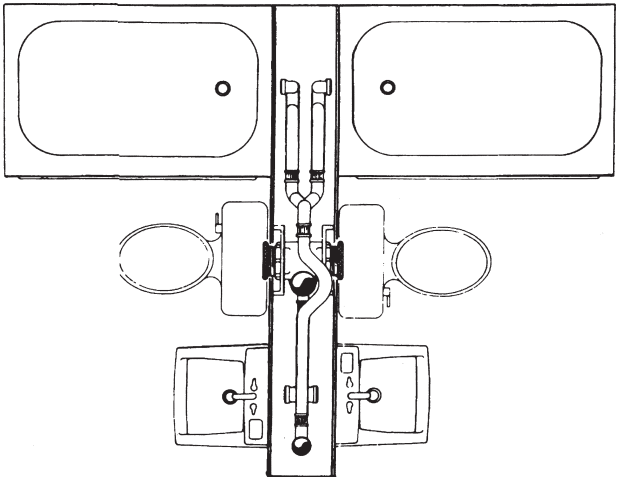
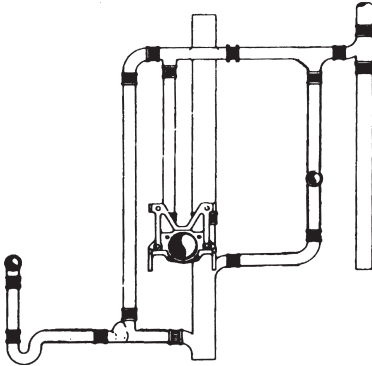

N  
O  
-  
H  
U  
B

**PART NO. EZS 400D**

**Charlotte Pipe Starter Fitting  
4x30 Closet Fitting Double - M Inlet 0; B Inlet 6 1/2"**

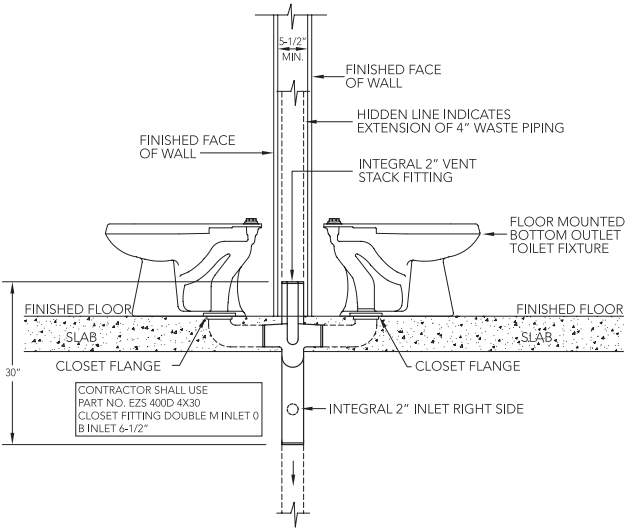

DOUBLE FITTING IN-SLAB - LEFT SIDE ELEVATION

**PART NO. EZS 700D**

**Charlotte Pipe Starter Fitting  
4x28 Threaded Double - A Inlet 0; B Inlet 8 1/2"  
with EZS 22 Support Frame and EZS 24 Trim Package**

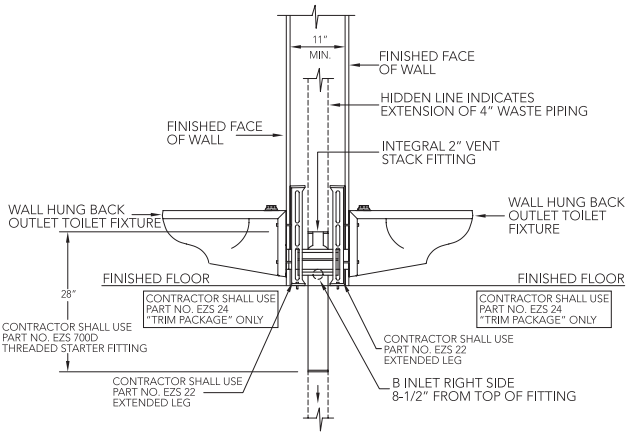

DOUBLE FITTING - LEFT SIDE ELEVATION

DETAIL DRAWINGS

**PART NO. EZS 700R**

**Charlotte Pipe Starter Fitting  
4x28 Threaded Right Hand - A Inlet 0; B Inlet 0  
with EZS 23 Trim Package**

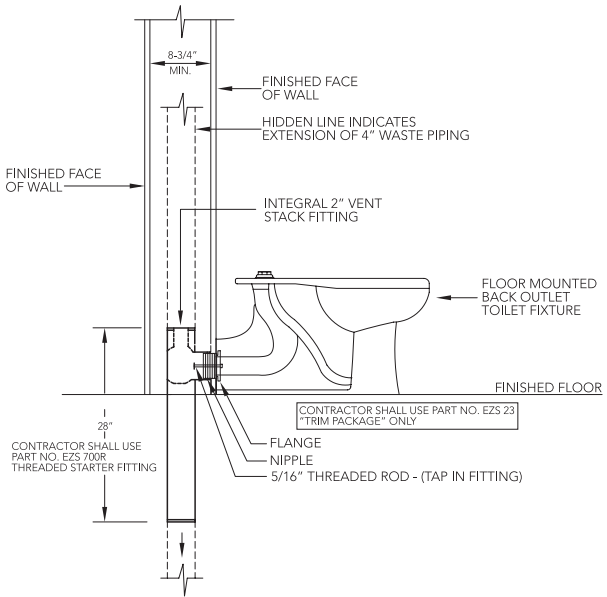

RIGHT HAND FITTING - LEFT SIDE ELEVATION

**PART NO. EZS 800D**

**Charlotte Pipe Starter Fitting  
4x28 Threaded Double - A Inlet 16; B Inlet 0  
with EZS 23 Trim Package**

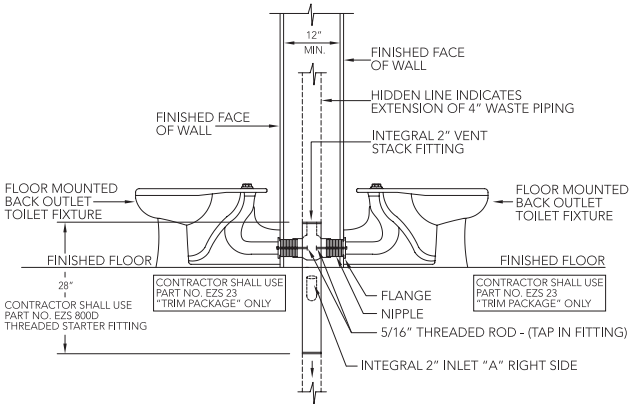

DOUBLE FITTING - LEFT SIDE ELEVATION

**DETAIL  
DRAWINGS**

**PART NO. EZS 800L**

**Charlotte Pipe Starter Fitting  
4x28 Threaded Left Hand - A Inlet 16; B Inlet 0  
with EZS 22 Support Frame and EZS 24 Trim Package**

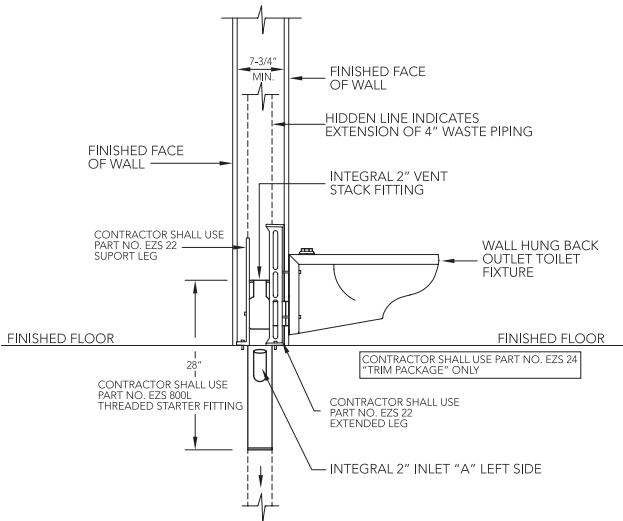

LEFT HAND FITTING - LEFT SIDE ELEVATION

**PART NO. NH 458**

**Charlotte Pipe Starter Fitting  
4x4x2x2x4 Vented Closet Tee, Left Hand,  
with 2" Top Vent and 2" Side Inlet**

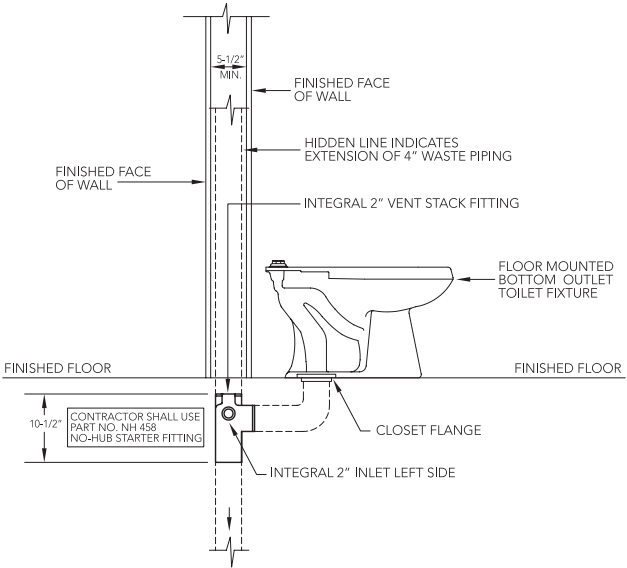

SINGLE FITTING LEFT HAND UNDER-SLAB - LEFT SIDE ELEVATION

**PART NO. NH 502**

**Charlotte Pipe Starter Fitting  
4" No-Hub with 2" Top Vent and 2" 45° Tap Service  
for Two Cells at 45° Angle**

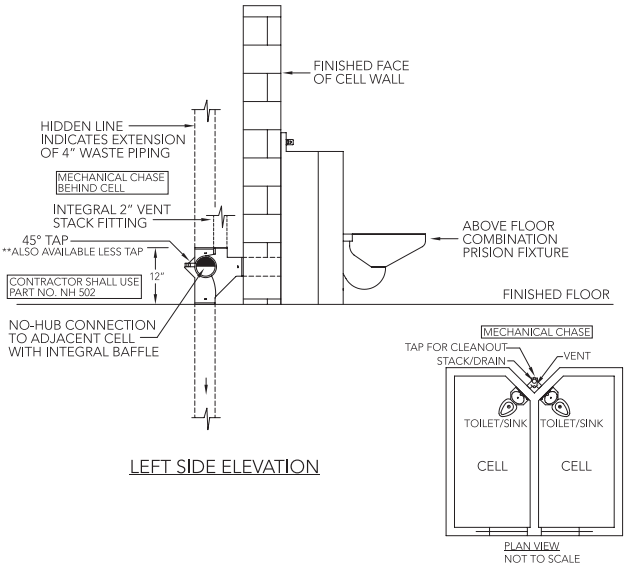

# Service

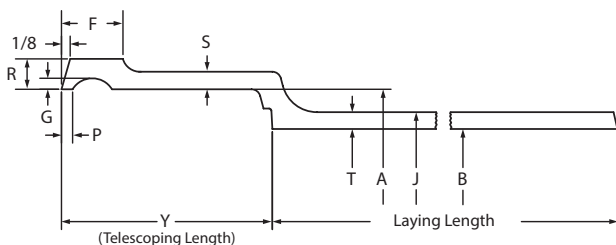

## PIPE - SERVICE\*

Size	Telescoping Length	Hub I.D.	O.D.	Barrel I.D.	Nominal Thickness
	Y	A	J	B	T
2"	2.50	2.94	2.30	1.96	0.17
3"	2.75	3.94	3.30	2.96	0.17
4"	3.00	4.94	4.30	3.94	0.18
5"	3.00	5.94	5.30	4.94	0.18
6"	3.00	6.94	6.30	5.94	0.18
8"	3.50	9.25	8.38	7.94	0.23
10"	3.50	11.38	10.50	9.94	0.28
12"	4.24	13.50	12.50	11.94	0.28
15"	4.25	16.95	15.88	15.16	0.36

## CHARLOTTE® SPEED-PAK FIVE FOOT PIPE BUNDLES

SERVICE				
	SIZE	PIECES	WEIGHT	HEIGHT
Single Hub	2"	100	2248	20"
	3"	60	1910	22"
	4"	46	1904	25"
	5"	33	1750	31"
	6"	23	1591	31"
	8"	11	1128	30"
	10"	8	1226	27"
	12"	6	1114	31"
Double Hub	15"	2	575	34"
	2"	100	2113	23"
	3"	60	1914	24"
	4"	46	1956	25"
	5"	33	1888	35"
	6"	23	1598	35"

\* For additional dimensional information please see the Cast Iron Technical and Installation Manual.

S  
E  
R  
V  
I  
C  
E

**CHARLOTTE® SPEED-PAK**  
**30" SINGLE HUB PIPE BUNDLES**

SERVICE				
30" Single Hub	SIZE	PIECES	WEIGHT	HEIGHT
	8 x 30"	11	645	24"
	10 x 30"	8	733	24"
	12 x 30"	6	643	28"
	15 x 30"	2	333	34"

**TEN FOOT PIPE BUNDLES**

SERVICE				
Single Hub	SIZE	PIECES	WEIGHT	HEIGHT
	2 x 10'	54	2165	12"
	3 x 10'	36	2141	15"
	4 x 10'	27	2028	18"
	5 x 10'	24	2409	20"
	6 x 10'	18	2211	23"
	8 x 10'	8	1444	22"
	10 x 10'	6	1558	27"
	12 x 10'	6	2075	30"
	15 x 10'	2	1050	23"

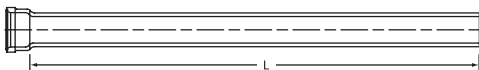
**PART NO. SV 1**

**Pipe, 5' Lengths, Single Hub**

Size	L	Weight
2" x 5'	5'	23.8
3" x 5'	5'	31.8
4" x 5'	5'	41.0
5" x 5'	5'	52.5
6" x 5'	5'	69.2
8" x 5'	5'	101.0
10" x 5'	5'	150.9
12" x 5'	5'	185.7
15" x 5'	5'	302.7

Weights are approximate and are for shipping purposes only.

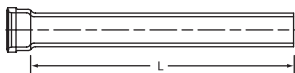
## PART NO. SV 1A



## Pipe, 30" Lengths, Single Hub

Size	L	Weight
8" x 30"	30"	58.7
10" x 30"	30"	91.7
12" x 30"	30"	107.1
15" x 30"	30"	166.3

## PART NO. SV 2

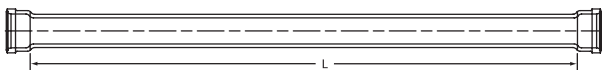

## Pipe, 5' Lengths, Double Hub

Size	L	Weight
2" x 5'	4' 9 $\frac{1}{2}$ "	21.1
3" x 5'	4' 9 $\frac{1}{4}$ "	31.9
4" x 5'	4' 9"	42.5
5" x 5'	4' 9"	57.2
6" x 5'	4' 9"	69.5

## PART NO. SV 3

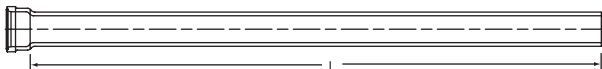

## Pipe, 10' Lengths, Single Hub

Size	L	Weight
2" x 10'	10'	40.1
3" x 10'	10'	59.5
4" x 10'	10'	75.1
5" x 10'	10'	100.4
6" x 10'	10'	122.8
8" x 10'	10'	180.5
10" x 10'	10'	276.1
12" x 10'	10'	345.9
15" x 10'	10'	525.1

**PART NO. SV 4**

**Pipe, 30" Lengths, Double Hub**

Size	L	Weight
2" x 30"	25"	13.8
3" x 30"	24 1/2"	17.6
4" x 30"	24"	27.1

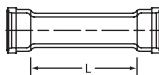

**PART NO. SV 900**

**Service Weight Charlotte Seal Gasket**

Size	A	D	F	G	H	Weight
2	3 1/2	2 3/16	2 1/8	3 1/8	1 31/32	0.3
3	4 1/2	3 3/16	3 1/8	4 1/8	2 1/16	0.4
4	5 1/2	4 3/16	4 1/8	5 1/4	2 9/32	0.5
5	6 1/2	5 3/16	5 1/8	6 1/4	2 9/32	0.6
6	7 1/2	6 3/16	6 1/8	7 1/4	2 1/4	0.8
8	9 3/4	8 13/32	8 3/16	9 9/32	3	1.5
10	12 7/16	10 1/2	10 5/16	11 11/16	2 3/4	2.4

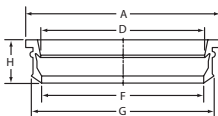

**PART NO. SV 950**

**Service Weight Quik-Tite Gasket**

Size	A	D	F	G	H	Weight
2	3 1/2	2 1/16	2	3 1/4	1 3/32	0.3
3	4 7/8	3 1/16	3 1/16	4 3/8	1 3/4	0.4
4	5 3/4	4	4	5 3/16	1 3/4	0.5
5	6 3/4	5	5	6	2 1/16	0.8
6	8	6 5/16	6 5/16	7 11/32	2 5/32	0.8
8	10	8 3/16	8 3/16	8 1/2	2 1/2	1.5
10	12 1/4	10 1/4	10	11 1/2	2 1/2	2.3
12	14 3/8	12 1/4	12	14	2 7/8	3.0

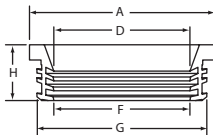

## PART NO. SV 5

## Quarter Bend

Size	D	X	Weight
2	6	3 <sup>1</sup> / <sub>4</sub>	5.1
3	7	4	7.7
4	8	4 <sup>1</sup> / <sub>2</sub>	13.1
5	8 <sup>1</sup> / <sub>2</sub>	5	16.2
6	9	5 <sup>1</sup> / <sub>2</sub>	21.7
8	11 <sup>1</sup> / <sub>2</sub>	6 <sup>5</sup> / <sub>8</sub>	36.5
10	12 <sup>1</sup> / <sub>2</sub>	7 <sup>5</sup> / <sub>8</sub>	57.3
12	15	8 <sup>3</sup> / <sub>4</sub>	82.8
15	(HX)	(HX)	(HX)

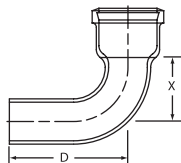

## PART NO. SV 7

## Sixth Bend

Size	D	X	Weight
2	4 <sup>3</sup> / <sub>4</sub>	2	4.3
3	5 <sup>1</sup> / <sub>2</sub>	2 <sup>1</sup> / <sub>2</sub>	6.9
4	6 <sup>5</sup> / <sub>16</sub>	2 <sup>13</sup> / <sub>16</sub>	10.8
5	6 <sup>5</sup> / <sub>8</sub>	3 <sup>1</sup> / <sub>8</sub>	14.0
6	6 <sup>7</sup> / <sub>8</sub>	3 <sup>3</sup> / <sub>8</sub>	16.4
8	9	4 <sup>1</sup> / <sub>8</sub>	32.5

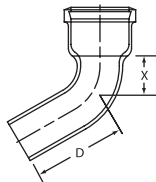

(HX) Please see Extra Heavy dimensions

## PART NO. SV 8

## Eighth Bend

Size	D	X	Weight
2	4 <sup>1</sup> / <sub>4</sub>	1 <sup>1</sup> / <sub>2</sub>	4.2
3	4 <sup>15</sup> / <sub>16</sub>	1 <sup>15</sup> / <sub>16</sub>	6.5
4	5 <sup>11</sup> / <sub>16</sub>	2 <sup>3</sup> / <sub>16</sub>	10.7
5	5 <sup>7</sup> / <sub>8</sub>	2 <sup>3</sup> / <sub>8</sub>	13.1
6	6 <sup>1</sup> / <sub>16</sub>	2 <sup>9</sup> / <sub>16</sub>	16.6
8	8	3 <sup>1</sup> / <sub>8</sub>	32.3
10	8 <sup>3</sup> / <sub>8</sub>	3 <sup>1</sup> / <sub>2</sub>	44.1
12	10 <sup>5</sup> / <sub>16</sub>	4 <sup>1</sup> / <sub>16</sub>	65.4
15	(XH)	(XH)	(XH)

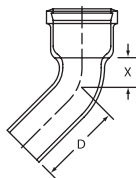

## PART NO. SV 9

## Sixteenth Bend

Size	D	X	Weight
2	3 <sup>5</sup> / <sub>8</sub>	7 <sup>7</sup> / <sub>8</sub>	3.4
3	4 <sup>3</sup> / <sub>16</sub>	1 <sup>3</sup> / <sub>16</sub>	6.0
4	4 <sup>13</sup> / <sub>16</sub>	1 <sup>5</sup> / <sub>16</sub>	8.8
5	4 <sup>7</sup> / <sub>8</sub>	1 <sup>3</sup> / <sub>8</sub>	11.6
6	5	1 <sup>1</sup> / <sub>2</sub>	13.8
8	6 <sup>11</sup> / <sub>16</sub>	1 <sup>13</sup> / <sub>16</sub>	24.6
10	6 <sup>7</sup> / <sub>8</sub>	2	37.1
12	8 <sup>5</sup> / <sub>8</sub>	2 <sup>3</sup> / <sub>8</sub>	57.7
15	(XH)	(XH)	(XH)

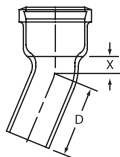

(HX) Please see Extra Heavy dimensions

**PART NO. SV 10**

**Quarter Bend with Low Heel Inlet**

Size	D	X	X'	Weight
3 x 2	7	4	9	9.8
4 x 2	8	4½	10½	13.0

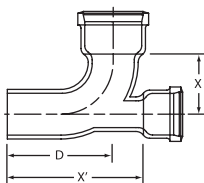

**PART NO. SV 12**

**Quarter Bend with Side Opening**

Size	D	X	Weight
4w2LH	8	3½	16.2
4w2RH	8	3½	16.5

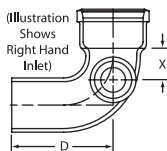

**PART NO. SV 15**

**Double Quarter Bend**

Size	D	X	Weight
4	8	4½	15.0

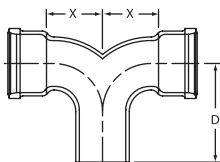

**PART NO. SV 18**

**Reducing Quarter Bend**

Size	D	X	Weight
3 x 2	7	3 <sup>3</sup> / <sub>8</sub>	7.0
4 x 2	7 <sup>1</sup> / <sub>2</sub>	4 <sup>1</sup> / <sub>2</sub>	11.7
4 x 3	8 <sup>1</sup> / <sub>8</sub>	4 <sup>3</sup> / <sub>8</sub>	9.1

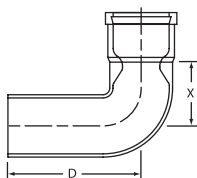

**PART NO. SV 23**

**Single Hub Return Bend**

Size	D	X	J	Weight
3	5 <sup>5</sup> / <sub>8</sub>	5	5 <sup>7</sup> / <sub>8</sub>	9.4
4	7 <sup>1</sup> / <sub>2</sub>	6 <sup>11</sup> / <sub>32</sub>	7 <sup>3</sup> / <sub>16</sub>	16.4

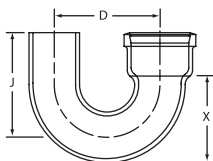

**PART NO. SV 25**

**Long Quarter Bend**

Size	D	X	Weight
2 x 12	12	3 <sup>1</sup> / <sub>4</sub>	6.9
3 x 12	12	4	10.3
4 x 12	12	4 <sup>1</sup> / <sub>2</sub>	15.4
4 x 16	16	4 <sup>1</sup> / <sub>2</sub>	20.4
4 x 18	18	4 <sup>1</sup> / <sub>2</sub>	21.4
4 x 24	24	4 <sup>1</sup> / <sub>2</sub>	27.9

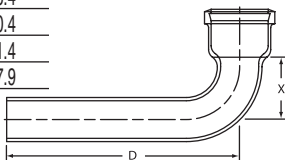

## PART NO. SV 26

## Long Eighth Bend

Size	D	X	Weight
2 x 12	12	1½	6.2
3 x 12	12	1 <sup>15</sup> / <sub>16</sub>	9.9
3 x 18	18	1 <sup>15</sup> / <sub>16</sub>	12.4
4 x 12	12	2 <sup>3</sup> / <sub>16</sub>	15.6
4 x 18	18	2 <sup>3</sup> / <sub>16</sub>	20.6
6 x 18	18	2 <sup>9</sup> / <sub>16</sub>	31.0

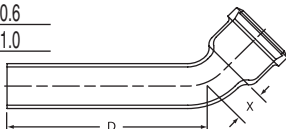

## PART NO. SV 29

## Short Sweep Bend

Size	D	X	Weight
2	8	5¼	6.2
3	9	6	9.4
4	10	6½	16.6
5	10½	7	20.7
6	11	7½	26.6
8	13½	8 <sup>5</sup> / <sub>8</sub>	37.4
10	14½	9 <sup>5</sup> / <sub>8</sub>	71.5
12	17	10 <sup>3</sup> / <sub>4</sub>	100.6

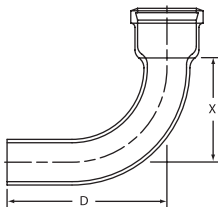

**PART NO. SV 30**

**Long Sweep Bend**

Size	D	X	Weight
2	11	8 <sup>1</sup> / <sub>4</sub>	7.6
3	12	9	12.2
4	13	9 <sup>1</sup> / <sub>2</sub>	21.2
5	13 <sup>1</sup> / <sub>2</sub>	10	25.3
6	14	10 <sup>1</sup> / <sub>2</sub>	29.9
8	16 <sup>1</sup> / <sub>2</sub>	11 <sup>5</sup> / <sub>8</sub>	52.9
10	17 <sup>1</sup> / <sub>2</sub>	12 <sup>5</sup> / <sub>8</sub>	82.6
12	20	13 <sup>3</sup> / <sub>4</sub>	103.5
15	(XH)	(XH)	(XH)

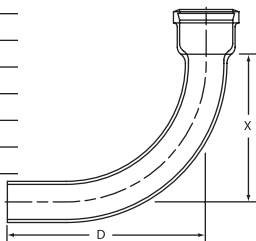

**PART NO. SV 31**

**Reducing Long Sweep Bend**

Size	D	X	Weight
3 x 2	12	9	12.0
4 x 3	13	9 <sup>1</sup> / <sub>2</sub>	17.6

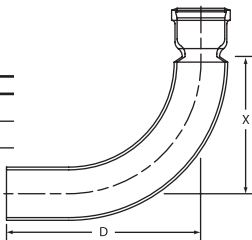

**PART NO. SV 32**

**Combination Wye & Eighth Bend  
(Charlotte Pattern)**

Size	G	H	X	X'	Weight
4	5 <sup>7</sup> / <sub>16</sub>	4 <sup>3</sup> / <sub>8</sub>	11 <sup>3</sup> / <sub>8</sub>	6 <sup>1</sup> / <sub>2</sub>	20.3

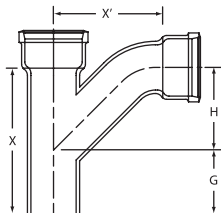

(XH) Please see Extra Heavy dimensions

## PART NO. SV 33

**Combination Wye & Eighth Bend  
 (Long Turn Pattern)**

Size	G	H	X	X'	Weight
2 x 2	4	3 <sup>3</sup> / <sub>8</sub>	8	4 <sup>7</sup> / <sub>8</sub>	8.6
3 x 2	4 <sup>3</sup> / <sub>16</sub>	4	9	5 <sup>3</sup> / <sub>4</sub>	11.1
3 x 3	5	5 <sup>1</sup> / <sub>16</sub>	10 <sup>1</sup> / <sub>2</sub>	7	14.8
4 x 2	3 <sup>11</sup> / <sub>16</sub>	4 <sup>1</sup> / <sub>2</sub>	9	6 <sup>1</sup> / <sub>4</sub>	15.5
4 x 3	4 <sup>1</sup> / <sub>2</sub>	5 <sup>9</sup> / <sub>16</sub>	10 <sup>1</sup> / <sub>2</sub>	7 <sup>1</sup> / <sub>2</sub>	19.2
4 x 4	4 <sup>1</sup> / <sub>2</sub>	7 <sup>1</sup> / <sub>2</sub>	12	9	24.5
5 x 2	3 <sup>3</sup> / <sub>8</sub>	5	9	6 <sup>3</sup> / <sub>4</sub>	14.6
5 x 3	4	6 <sup>1</sup> / <sub>16</sub>	10 <sup>1</sup> / <sub>2</sub>	8	21.3
5 x 4	4 <sup>1</sup> / <sub>4</sub>	7 <sup>5</sup> / <sub>16</sub>	12	9 <sup>1</sup> / <sub>2</sub>	25.9
5 x 5	5 <sup>1</sup> / <sub>2</sub>	8 <sup>5</sup> / <sub>8</sub>	13 <sup>1</sup> / <sub>2</sub>	11	33.6
6 x 2	2 <sup>11</sup> / <sub>16</sub>	5 <sup>1</sup> / <sub>2</sub>	9	7 <sup>1</sup> / <sub>4</sub>	19.6
6 x 3	3 <sup>1</sup> / <sub>8</sub>	6 <sup>9</sup> / <sub>16</sub>	10 <sup>1</sup> / <sub>4</sub>	8 <sup>1</sup> / <sub>2</sub>	24.7
6 x 4	4 <sup>1</sup> / <sub>4</sub>	7 <sup>13</sup> / <sub>16</sub>	12	10	31.7
6 x 5	5 <sup>1</sup> / <sub>16</sub>	9 <sup>1</sup> / <sub>8</sub>	13 <sup>1</sup> / <sub>2</sub>	11 <sup>1</sup> / <sub>2</sub>	34.3
6 x 6	5 <sup>3</sup> / <sub>4</sub>	10 <sup>5</sup> / <sub>16</sub>	15	12 <sup>7</sup> / <sub>8</sub>	44.2
8 x 2	3 <sup>1</sup> / <sub>8</sub>	6 <sup>1</sup> / <sub>2</sub>	10 <sup>1</sup> / <sub>2</sub>	8 <sup>1</sup> / <sub>4</sub>	34.0
8 x 4	4 <sup>3</sup> / <sub>4</sub>	8 <sup>13</sup> / <sub>16</sub>	13 <sup>1</sup> / <sub>2</sub>	11	40.1
8 x 5	5 <sup>1</sup> / <sub>2</sub>	10 <sup>1</sup> / <sub>8</sub>	15	12 <sup>1</sup> / <sub>2</sub>	49.6
8 x 6	6 <sup>5</sup> / <sub>16</sub>	11 <sup>5</sup> / <sub>16</sub>	16 <sup>1</sup> / <sub>2</sub>	13 <sup>7</sup> / <sub>8</sub>	55.7
8 x 8	7 <sup>1</sup> / <sub>16</sub>	13 <sup>7</sup> / <sub>8</sub>	19 <sup>1</sup> / <sub>2</sub>	17	85.6

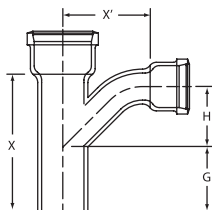

## PART NO. SV 35

**Double Combination Wye & Eighth Bend  
 (Charlotte Pattern)**

Size	G	H	X	X'	Weight
4	5 <sup>7</sup> / <sub>16</sub>	4 <sup>3</sup> / <sub>8</sub>	11 <sup>3</sup> / <sub>8</sub>	6 <sup>1</sup> / <sub>2</sub>	26.0

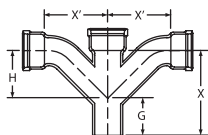

## PART NO. SV 35F

**Double Combination Wye & Eighth Bend  
 (Long Turn Pattern)**

Size	G	H	X	X'	Weight
2 x 2	4	3 <sup>3</sup> / <sub>8</sub>	8	4 <sup>7</sup> / <sub>8</sub>	12.0
3 x 2	4 <sup>3</sup> / <sub>16</sub>	4	9	5 <sup>3</sup> / <sub>4</sub>	14.6
3 x 3	5	5 <sup>1</sup> / <sub>16</sub>	10 <sup>1</sup> / <sub>2</sub>	7	22.0
4 x 2	3 <sup>11</sup> / <sub>16</sub>	4 <sup>1</sup> / <sub>2</sub>	9	6 <sup>1</sup> / <sub>4</sub>	19.7
4 x 3	4 <sup>1</sup> / <sub>2</sub>	5 <sup>9</sup> / <sub>16</sub>	10 <sup>1</sup> / <sub>2</sub>	7 <sup>1</sup> / <sub>2</sub>	26.5
4 x 4	5 <sup>1</sup> / <sub>4</sub>	6 <sup>13</sup> / <sub>16</sub>	12	9	36.2
5 x 4	4 <sup>1</sup> / <sub>4</sub>	7 <sup>5</sup> / <sub>16</sub>	12	9 <sup>1</sup> / <sub>2</sub>	30.9
6 x 4	4 <sup>1</sup> / <sub>4</sub>	7 <sup>13</sup> / <sub>16</sub>	12	10	41.0
6 x 6	5 <sup>3</sup> / <sub>4</sub>	10 <sup>5</sup> / <sub>16</sub>	15	12 <sup>7</sup> / <sub>8</sub>	69.6

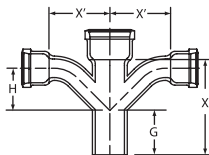

## PART NO. SV 35F

**Double Combination Wye & Eighth Bend  
 with 2" Cup Hub Inlet**

Size	G	G'	H	X	X'	Weight
4	4 <sup>1</sup> / <sub>4</sub>	10	12 <sup>1</sup> / <sub>16</sub>	12	9	41.7

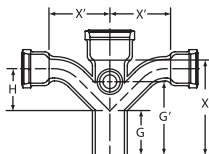

## PART NO. SV 39A

**Combination Wye & Eighth Bend  
 with Side Inlet**

Size	G'	H	X	X'	Weight
4w/2RH	10	12 <sup>1</sup> / <sub>16</sub>	12	9	27.3
4w/2LH	10	12 <sup>1</sup> / <sub>16</sub>	12	9	28.3

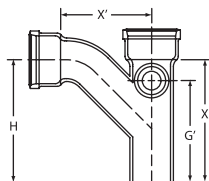

## PART NO. SV 41

**Combination Wye & Eighth Bend  
 with Cleanout on Main**

Size	IPS Tap	G	X	X'	Weight
4	3 <sup>1</sup> / <sub>2</sub>	9	12 <sup>3</sup> / <sub>16</sub>	12 <sup>1</sup> / <sub>4</sub>	18.9

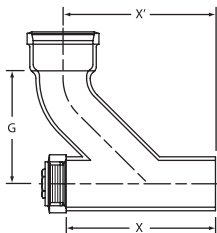

**PART NO. SV 42**

**Straight Tee**

Size	G	X	X'	Weight
2 x 2	6 <sup>1</sup> / <sub>4</sub>	8	1 <sup>3</sup> / <sub>4</sub>	7.0
3 x 2	7	9	2 <sup>1</sup> / <sub>2</sub>	9.0
3 x 3	7 <sup>1</sup> / <sub>2</sub>	10	2 <sup>1</sup> / <sub>2</sub>	12.0
4 x 2	7	9	3	12.7
4 x 3	7 <sup>1</sup> / <sub>2</sub>	10	3	14.0
4 x 4	8	11	3	16.6
5 x 5	8 <sup>1</sup> / <sub>2</sub>	12	3 <sup>1</sup> / <sub>2</sub>	19.0
6 x 4	8	11	4	19.9
6 x 6	9	13	4	24.0
8 x 4	9 <sup>5</sup> / <sub>8</sub>	12 <sup>7</sup> / <sub>8</sub>	5 <sup>1</sup> / <sub>4</sub>	37.0

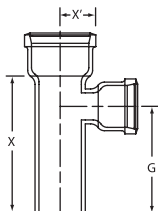

## PART NO. SV 43

## Sanitary Tee

Size	G	X	X'	Weight
2 x 2	6 <sup>1</sup> / <sub>4</sub>	8	2 <sup>3</sup> / <sub>4</sub>	7.9
3 x 2	7	9	4	10.9
3 x 3	7 <sup>1</sup> / <sub>2</sub>	10	4	11.9
4 x 2	7	9	4 <sup>1</sup> / <sub>2</sub>	14.2
4 x 3	7 <sup>1</sup> / <sub>2</sub>	10	4 <sup>1</sup> / <sub>2</sub>	16.9
4 x 4	8	11	4 <sup>1</sup> / <sub>2</sub>	18.6
5 x 4	8	11	5	17.9
5 x 5	8 <sup>1</sup> / <sub>2</sub>	12	5	22.3
6 x 2	7	9	5 <sup>1</sup> / <sub>2</sub>	15.0
6 x 3	7 <sup>1</sup> / <sub>2</sub>	10	5 <sup>1</sup> / <sub>2</sub>	21.4
6 x 4	8	11	5 <sup>1</sup> / <sub>2</sub>	22.8
6 x 6	9	13	5 <sup>1</sup> / <sub>2</sub>	29.8
8 x 4	9 <sup>3</sup> / <sub>4</sub>	13	6 <sup>1</sup> / <sub>2</sub>	35.7
8 x 6	10 <sup>3</sup> / <sub>4</sub>	15	6 <sup>1</sup> / <sub>2</sub>	43.0
8 x 8	11 <sup>3</sup> / <sub>4</sub>	17	6 <sup>5</sup> / <sub>8</sub>	50.8
10 x 4	9 <sup>3</sup> / <sub>4</sub>	13	7 <sup>1</sup> / <sub>2</sub>	52.0
10 x 6	10 <sup>3</sup> / <sub>4</sub>	15	7 <sup>1</sup> / <sub>2</sub>	57.7
10 x 8	11 <sup>3</sup> / <sub>4</sub>	17	7 <sup>5</sup> / <sub>8</sub>	68.0
10 x 10	12 <sup>3</sup> / <sub>4</sub>	19	7 <sup>5</sup> / <sub>8</sub>	75.9
12 x 6	12	16 <sup>1</sup> / <sub>2</sub>	8 <sup>1</sup> / <sub>2</sub>	79.0
12 x 8	13	18 <sup>1</sup> / <sub>2</sub>	8 <sup>5</sup> / <sub>8</sub>	104.0
12 x 10	14	20 <sup>1</sup> / <sub>2</sub>	8 <sup>5</sup> / <sub>8</sub>	123.0
12 x 12	15	22 <sup>1</sup> / <sub>2</sub>	8 <sup>3</sup> / <sub>4</sub>	113.0
15 x 6	12	16 <sup>1</sup> / <sub>2</sub>	10	145.0
15 x 8	13	18 <sup>1</sup> / <sub>2</sub>	10 <sup>1</sup> / <sub>8</sub>	173.0
15 x 12	15	22 <sup>1</sup> / <sub>2</sub>	10 <sup>1</sup> / <sub>4</sub>	204.0
15 x 15	(XH)	(XH)	(XH)	(XH)

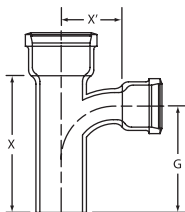

(XH) Please see Extra Heavy dimensions

## PART NO. SV 44

## Wye

Size	G	X	X'	Weight
2 x 2	4	8	4	8.3
3 x 2	4 <sup>3</sup> / <sub>16</sub>	9	5	10.9
3 x 3	5	10 <sup>1</sup> / <sub>2</sub>	5 <sup>1</sup> / <sub>2</sub>	12.2
4 x 2	3 <sup>5</sup> / <sub>8</sub>	9	5 <sup>3</sup> / <sub>4</sub>	14.4
4 x 3	4 <sup>7</sup> / <sub>16</sub>	10 <sup>1</sup> / <sub>2</sub>	6 <sup>1</sup> / <sub>4</sub>	16.8
4 x 4	5 <sup>1</sup> / <sub>4</sub>	12	6 <sup>3</sup> / <sub>4</sub>	20.3
5 x 2	3 <sup>1</sup> / <sub>8</sub>	9	6 <sup>1</sup> / <sub>2</sub>	15.3
5 x 3	3 <sup>7</sup> / <sub>8</sub>	10 <sup>1</sup> / <sub>2</sub>	7	19.8
5 x 4	4 <sup>11</sup> / <sub>16</sub>	12	7 <sup>1</sup> / <sub>2</sub>	23.0
5 x 5	5 <sup>1</sup> / <sub>2</sub>	13 <sup>1</sup> / <sub>2</sub>	8	27.0
6 x 2	2 <sup>9</sup> / <sub>16</sub>	9	7 <sup>1</sup> / <sub>4</sub>	19.7
6 x 3	3 <sup>3</sup> / <sub>8</sub>	10 <sup>1</sup> / <sub>2</sub>	7 <sup>3</sup> / <sub>4</sub>	23.7
6 x 4	4 <sup>3</sup> / <sub>16</sub>	12	8 <sup>1</sup> / <sub>4</sub>	26.7
6 x 5	4 <sup>15</sup> / <sub>16</sub>	13 <sup>1</sup> / <sub>2</sub>	8 <sup>3</sup> / <sub>4</sub>	29.5
6 x 6	5 <sup>3</sup> / <sub>4</sub>	15	9 <sup>1</sup> / <sub>4</sub>	36.5
8 x 2	3 <sup>1</sup> / <sub>8</sub>	10 <sup>1</sup> / <sub>2</sub>	8 <sup>1</sup> / <sub>2</sub>	31.0
8 x 3	3 <sup>15</sup> / <sub>16</sub>	12	9	33.2
8 x 4	4 <sup>3</sup> / <sub>4</sub>	13 <sup>1</sup> / <sub>2</sub>	9 <sup>1</sup> / <sub>2</sub>	38.3
8 x 5	5 <sup>1</sup> / <sub>2</sub>	15	10	41.2
8 x 6	6 <sup>5</sup> / <sub>16</sub>	16 <sup>1</sup> / <sub>2</sub>	10 <sup>1</sup> / <sub>2</sub>	45.4
8 x 8	7 <sup>1</sup> / <sub>16</sub>	19 <sup>1</sup> / <sub>2</sub>	11 <sup>13</sup> / <sub>16</sub>	58.4
10 x 3	2 <sup>3</sup> / <sub>4</sub>	12	10 <sup>3</sup> / <sub>4</sub>	54.0
10 x 4	3 <sup>9</sup> / <sub>16</sub>	13 <sup>1</sup> / <sub>2</sub>	11 <sup>1</sup> / <sub>8</sub>	55.4
10 x 5	4 <sup>5</sup> / <sub>16</sub>	15	11 <sup>5</sup> / <sub>8</sub>	60.6
10 x 6	5 <sup>1</sup> / <sub>8</sub>	16 <sup>1</sup> / <sub>2</sub>	12 <sup>1</sup> / <sub>8</sub>	64.1
10 x 8	6 <sup>1</sup> / <sub>2</sub>	19 <sup>1</sup> / <sub>2</sub>	13 <sup>7</sup> / <sub>16</sub>	86.9
10 x 10	8	22 <sup>1</sup> / <sub>2</sub>	14 <sup>1</sup> / <sub>2</sub>	111.1
12 x 4	4 <sup>1</sup> / <sub>8</sub>	15	12 <sup>7</sup> / <sub>16</sub>	69.7
12 x 5	4 <sup>7</sup> / <sub>8</sub>	16 <sup>1</sup> / <sub>2</sub>	12 <sup>15</sup> / <sub>16</sub>	78.0
12 x 6	5 <sup>1</sup> / <sub>16</sub>	18	13 <sup>7</sup> / <sub>16</sub>	87.7
12 x 8	7 <sup>1</sup> / <sub>16</sub>	21	14 <sup>3</sup> / <sub>4</sub>	100.6
12 x 10	8 <sup>9</sup> / <sub>16</sub>	24	15 <sup>13</sup> / <sub>16</sub>	131.0
12 x 12	10 <sup>1</sup> / <sub>8</sub>	27	16 <sup>7</sup> / <sub>8</sub>	175.2
15 x 4	6 <sup>3</sup> / <sub>8</sub>	15	15	138.5
15 x 6	4	18	15 <sup>3</sup> / <sub>4</sub>	153.6
15 x 8	5 <sup>3</sup> / <sub>8</sub>	21	17 <sup>1</sup> / <sub>16</sub>	187.1
15 x 10	6 <sup>7</sup> / <sub>8</sub>	24	18 <sup>1</sup> / <sub>8</sub>	225.0
15 x 12	8 <sup>7</sup> / <sub>16</sub>	27	19 <sup>3</sup> / <sub>16</sub>	260.0
15 x 15	(XH)	(XH)	(XH)	(XH)

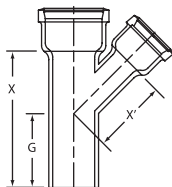

(XH) Please see Extra Heavy dimensions

**PART NO. SV 50**

**Sanitary Tee  
with Left Hand Side Tap**

Size	G	G'	X	X'	Weight
4w/2	8	9	11	4 1/2	16.3

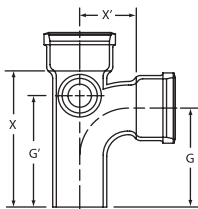

**PART NO. SV 50A**

**Sanitary Tee  
with Right Hand Side Tap**

Size	G	G'	X	X'	Weight
4w/2	8	9	11	4 1/2	16.5

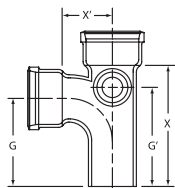

**PART NO. SV 50B**

**Sanitary Tee  
with Right and Left Hand Side Taps**

Size	G	G'	X	X'	Weight
4w/2	8	9	11	4 1/2	16.3

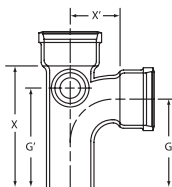

**PART NO. SV 56**

**Sanitary Tee with Left Hand Side Inlet**

Size	G	G'	X	X'	Weight
4w/2	8	9	11	4 1/2	20.2

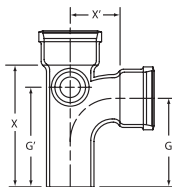

**PART NO. SV 56B**

**Sanitary Tee  
with Right Hand Side Inlet**

Size	G	G'	X	X'	Weight
4w/2	8	9	11	4 1/2	20.0

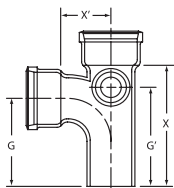

**PART NO. SV 56C**

**Sanitary Tee  
with Right and Left Hand Side Inlets**

Size	G	G'	X	X'	Weight
4w/2	8	9	11	4 1/2	23.1

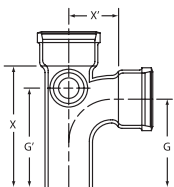

**PART NO. SV 57**

**Wye with Left Hand Side Inlet**

Size	G	G'	X	X'	Weight
4w/2	5 1/4	10	12	6 3/4	23.8

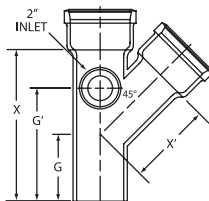

**PART NO. SV 57A**

**Wye with Right Hand Side Inlet**

Size	G	G'	X	X'	Weight
4w/2	5 1/4	10	12	6 3/4	23.8

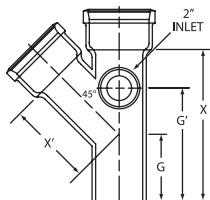

## PART NO. SV 71A

## Single Two-Way Cleanout

Size	X	E'	G	Weight
4	22 <sup>7</sup> / <sub>16</sub>	9 <sup>3</sup> / <sub>8</sub>	12 <sup>3</sup> / <sub>4</sub>	33.5

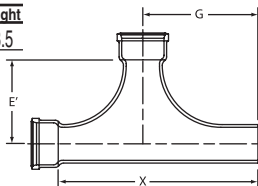

## PART NO. SV 71B

## Short Special Two-Way Cleanout

Size	G	X	X'	Weight
4	8	12	4	16.0

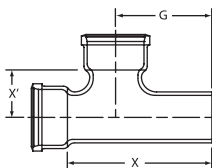

## PART NO. SV 72

## Double Two-Way Cleanout

Size	G	J	X	X'	Weight
4	6 <sup>1</sup> / <sub>2</sub>	6 <sup>7</sup> / <sub>16</sub>	13 <sup>5</sup> / <sub>8</sub>	7 <sup>1</sup> / <sub>2</sub>	31.2
6 x 4 x 4	6 <sup>1</sup> / <sub>2</sub>	6 <sup>7</sup> / <sub>16</sub>	13 <sup>5</sup> / <sub>8</sub>	8 <sup>1</sup> / <sub>4</sub>	39.1

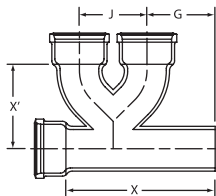

## PART NO. SV 76

## Sanitary Tee with Cleanout on Main

Size	IPS		G	X	X'	Weight
	Tap					
4	3 <sup>1</sup> / <sub>2</sub>		8	12 <sup>1</sup> / <sub>8</sub>	4 <sup>1</sup> / <sub>2</sub>	16.7

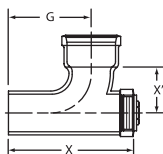

## PART NO. SV 79

Washington Test Tee<sup>‡</sup>

Size	IPS		E'	G	X	Weight
	Tap					
2	2		1 <sup>3</sup> / <sub>4</sub>	7	9	7.3
3	4		2 <sup>7</sup> / <sub>8</sub>	7 <sup>1</sup> / <sub>8</sub>	10 <sup>3</sup> / <sub>4</sub>	13.1
4	4		3 <sup>1</sup> / <sub>4</sub>	7 <sup>1</sup> / <sub>4</sub>	10 <sup>5</sup> / <sub>8</sub>	16.8
5	5		3 <sup>5</sup> / <sub>8</sub>	7	11	22.5
6	6		4	8 <sup>3</sup> / <sub>4</sub>	13	26.9
8	8		5	11	16 <sup>3</sup> / <sub>8</sub>	41.6
10	10		7 <sup>1</sup> / <sub>2</sub>	11	17 <sup>5</sup> / <sub>8</sub>	68.7

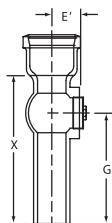

## PART NO. SV 80

## Cleanout Tee with Brass Plug

Size	IPS		E'	G	X	Weight
	Tap					
2	1 <sup>1</sup> / <sub>2</sub>		2	6 <sup>1</sup> / <sub>4</sub>	8	6.2
3	2		2 <sup>1</sup> / <sub>2</sub>	7	9	9.3
4	3		3	8	11	14.6
5	4		3 <sup>1</sup> / <sub>2</sub>	8 <sup>1</sup> / <sub>2</sub>	12	18.7
6	4		4 <sup>1</sup> / <sub>4</sub>	9	13	25.3
12	8		8	13	18 <sup>1</sup> / <sub>2</sub>	92.2

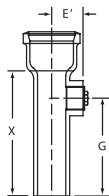

## PART NO. SV 81

## Miami Test Tee, Less Plug

## and PART NO. SV 81S

Miami Test Tee with Southern  
Raised-Head Brass Plug Installed

Size	IPS		E'	G	X	Weight
	Tap					
2	2		2 <sup>1</sup> / <sub>32</sub>	6 <sup>1</sup> / <sub>2</sub>	9	7.0
3	3		2 <sup>1</sup> / <sub>2</sub>	6 <sup>5</sup> / <sub>8</sub>	9 <sup>5</sup> / <sub>8</sub>	10.0
4	4		3	7 <sup>1</sup> / <sub>4</sub>	11	15.5
6	6		4	9	13 <sup>1</sup> / <sub>4</sub>	22.8

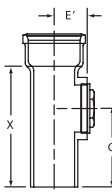

<sup>‡</sup> This fitting can be ordered without or with a Southern Raised Head Brass Plug installed (2" through 8" available with plug).

**PART NO. SV 82**

**Test Tee with Internal Tap**

Size	E'	G	X	Weight
4	2 <sup>15</sup> / <sub>16</sub>	7 <sup>7</sup> / <sub>8</sub>	12	15.9

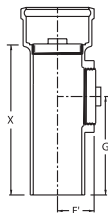

**PART NO. SV 83**

**Straight Tapped Tee**

Size	E'	G	X	Weight
2 x 1 <sup>1</sup> / <sub>2</sub>	2	6 <sup>1</sup> / <sub>4</sub>	8	5.5
2 x 2	2	6 <sup>1</sup> / <sub>4</sub>	8	6.0
3 x 1 <sup>1</sup> / <sub>2</sub>	2 <sup>1</sup> / <sub>2</sub>	7	9	7.4
3 x 2	2 <sup>1</sup> / <sub>2</sub>	7	9	8.6
4 x 2	3	7	9	12.3
4 x 3	4	8	11	14.0
4 x 4	3	7	9	15.0
5 x 2	3 <sup>1</sup> / <sub>2</sub>	7	9	13.5
5 x 4	3 <sup>1</sup> / <sub>2</sub>	8 <sup>1</sup> / <sub>2</sub>	12	17.9
6 x 4	4 <sup>1</sup> / <sub>4</sub>	9	13	24.4

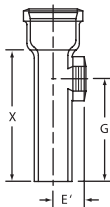

**PART NO. SV 84**

**Sanitary Tapped Tee**

Size	E'	G	X	Weight
2 x 1 <sup>1</sup> / <sub>2</sub>	2 <sup>13</sup> / <sub>16</sub>	6 <sup>1</sup> / <sub>4</sub>	8	6.0
2 x 2	3 <sup>1</sup> / <sub>16</sub>	6 <sup>1</sup> / <sub>4</sub>	8	5.8
3 x 1 <sup>1</sup> / <sub>2</sub>	3 <sup>5</sup> / <sub>16</sub>	7	9	8.0
3 x 2	3 <sup>9</sup> / <sub>16</sub>	7	9	8.1
4 x 1 <sup>1</sup> / <sub>2</sub>	3 <sup>13</sup> / <sub>16</sub>	7	9	10.3
4 x 2	4 <sup>1</sup> / <sub>16</sub>	7	9	11.7
4 x 3	4 <sup>1</sup> / <sub>16</sub>	8	11	13.6

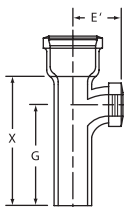

**PART NO. SV 85**

**Tapped Wye**

Size	G	X	X'	Weight
3 x 2	5	10 1/2	6 5/8	10.3
4 x 1 1/2	4 1/2	9	6 1/2	11.0
4 x 2	4 1/4	9	6	12.7

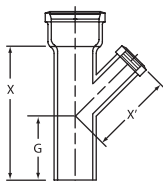

**PART NO. SV 89**

**Long Sanitary Tapped Tee**

Size	E'	G	X	Weight
2 x 2 x 18	3 1/16	16	18	8.8

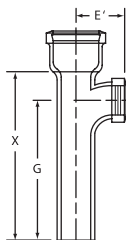

**PART NO. SV 91**

**Sanitary Tapped Cross**

Size	E'	G	X	Weight
2 x 1 1/2	2 13/16	6 1/4	8	11.3
2 x 2	3 1/16	6 1/4	8	6.7
3 x 2	3 9/16	7	9	9.0
4 x 2	4 1/16	7	9	11.6

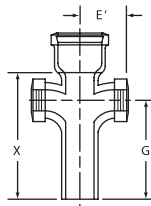

**PART NO. SV 92**

**Tapped Double Wye**

Size	G	X	X'	Weight
4 x 2	5 3/4	12	7 7/8	16.9

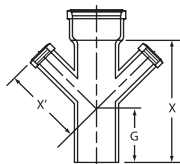

**PART NO. SV 93**

**Tapped Cross**

Size	E'	G	X	Weight
3 x 2	2 1/2	7	9	9.4
4 x 2	3	7	9	13.1

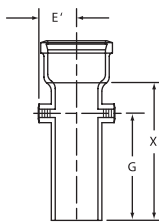

**PART NO. SV 108**

**Straight Cross**

Size	G	X	X'	Weight
4 x 2	7	9	3	16.0
4	8	11	3	17.0

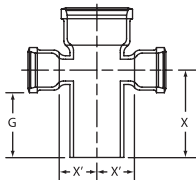

**PART NO. SV 109**

**Sanitary Cross**

Size	G	X	X'	Weight
2	6 1/4	8	2 3/4	10.0
3 x 2	7	9	4	12.5
3	7 1/2	10	4	15.6
4 x 2	7	9	4 1/2	16.0
4 x 3	7 1/2	10	4 1/2	20.0
4	8	11	4 1/2	22.9
5 x 4	8	11	5	23.2
6 x 4	8	11	5 1/2	29.0
6	9	13	5 1/2	34.9
8	11 3/4	17	6 5/8	105.0

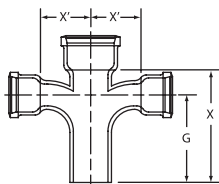

## PART NO. SV 110

## Double Wye

Size	G	X	X'	Weight
2	4	8	4	9.7
3 x 2	4 <sup>3</sup> / <sub>16</sub>	9	5	12.8
3	5	10 <sup>1</sup> / <sub>2</sub>	5 <sup>1</sup> / <sub>2</sub>	17.5
4 x 2	3 <sup>5</sup> / <sub>8</sub>	9	5 <sup>3</sup> / <sub>4</sub>	16.2
4 x 3	4 <sup>7</sup> / <sub>16</sub>	10 <sup>1</sup> / <sub>2</sub>	6 <sup>1</sup> / <sub>4</sub>	19.8
4	5 <sup>1</sup> / <sub>4</sub>	12	6 <sup>3</sup> / <sub>4</sub>	27.2
5	5 <sup>1</sup> / <sub>2</sub>	13 <sup>1</sup> / <sub>2</sub>	8	27.0
6 x 3	3 <sup>3</sup> / <sub>8</sub>	10 <sup>1</sup> / <sub>2</sub>	7 <sup>3</sup> / <sub>4</sub>	24.6
6 x 4	4 <sup>3</sup> / <sub>16</sub>	12	8 <sup>1</sup> / <sub>4</sub>	31.8
6	5 <sup>3</sup> / <sub>4</sub>	15	9 <sup>1</sup> / <sub>4</sub>	44.0
8 x 4	4 <sup>3</sup> / <sub>4</sub>	13 <sup>1</sup> / <sub>2</sub>	9 <sup>1</sup> / <sub>2</sub>	44.5
8 x 6	6 <sup>5</sup> / <sub>16</sub>	16 <sup>1</sup> / <sub>2</sub>	10 <sup>1</sup> / <sub>2</sub>	57.3
8	7 <sup>1</sup> / <sub>16</sub>	19 <sup>1</sup> / <sub>2</sub>	11 <sup>13</sup> / <sub>16</sub>	90.0
10 x 6	5 <sup>1</sup> / <sub>8</sub>	16 <sup>1</sup> / <sub>2</sub>	12 <sup>1</sup> / <sub>8</sub>	73.7
10 x 8	6 <sup>1</sup> / <sub>2</sub>	19 <sup>1</sup> / <sub>2</sub>	13 <sup>7</sup> / <sub>16</sub>	99.0
10	8	22 <sup>1</sup> / <sub>2</sub>	14 <sup>1</sup> / <sub>2</sub>	172.0
12 x 6	5 <sup>1</sup> / <sub>16</sub>	18	13 <sup>7</sup> / <sub>16</sub>	112.0
12 x 8	7 <sup>1</sup> / <sub>16</sub>	21	14 <sup>3</sup> / <sub>4</sub>	135.0
12	10 <sup>1</sup> / <sub>8</sub>	27	16 <sup>7</sup> / <sub>8</sub>	216.1
15	(XH)	(XH)	(XH)	(XH)

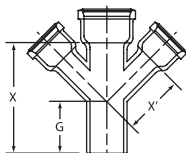

## PART NO. SV 114

## Sanitary Cross with 2" Side Inlet

Size	G	G'	X	X'	Weight
4	8	9	11	4 <sup>1</sup> / <sub>2</sub>	27.0

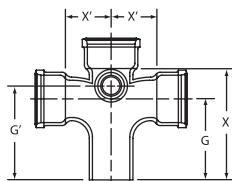

(XH) Please see Extra Heavy dimensions

**PART NO. SV 115**

**Double Wye with 2" Side Opening**

Size	G	H	X	X'	Weight
4 x 4	5 1/4	10	12	6 3/4	31.8

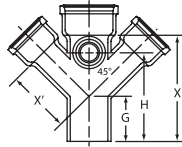

**PART NO. SV 135**

**"H" Branch**

Size	X	X'	J	G	Weight
4 x 3	12 3/16	7 9/16	6	4 1/2	17.0
4	13 15/16	8 11/16	6 1/2	5 1/4	19.6

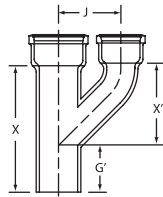

**PART NO. SV 137**

**Bar Grate with Legs**

Size	G	X	Weight
4	3	4 3/4	2.0

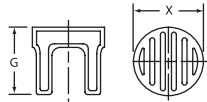

**PART NO. SV 141**

**45° Offset**

Size/Offset	X	G'	J	Weight
4 x 4	11	4	4	11.6
4 x 6	13	4	6	15.0
4 x 8	15	4	8	15.6

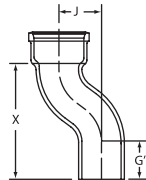

## PART NO. SV 143

## Reducer

Size	X	Weight
3 x 2	4 <sup>3</sup> / <sub>4</sub>	4.6
4 x 2	5	6.0
4 x 3	5	7.0
5 x 2	5	6.6
5 x 3	5	6.8
5 x 4	5	9.0
6 x 2	5	8.2
6 x 3	5	9.9
6 x 4	5	10.4
6 x 5	5	10.9
8 x 3	6	14.3
8 x 4	6	16.6
8 x 5	6	16.4
8 x 6	6	16.8
10 x 4	6	20.0
10 x 5	6	23.9
10 x 6	6	24.0
10 x 8	6	26.5
12 x 4	6 <sup>1</sup> / <sub>2</sub>	32.2
12 x 6	6 <sup>1</sup> / <sub>2</sub>	34.4
12 x 8	6 <sup>1</sup> / <sub>2</sub>	37.2
12 x 10	6 <sup>1</sup> / <sub>2</sub>	38.4
15 x 6	6 <sup>1</sup> / <sub>2</sub>	52.3
15 x 8	6 <sup>1</sup> / <sub>2</sub>	55.0
15 x 10	6 <sup>1</sup> / <sub>2</sub>	55.7
15 x 12	6 <sup>1</sup> / <sub>2</sub>	64.9

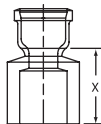

## PART NO. SV 144

## Reducer Increaser

Size	X	Weight
2 x 4	9	9.4
3 x 4	9	8.8
4 x 5	9	11.3
4 x 6	9	15.2
4 x 8	12	24.5
5 x 6	9	12.8
6 x 8	12	24.0
8 x 10	12	44.0

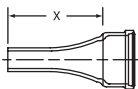

**PART NO. SV 147**

**Long Plain Increaser**

Size	X	Weight
3 x 4 x 24	24	13.6
4 x 5 x 30	30	27.4

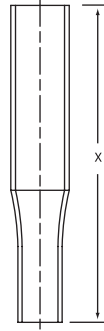

**PART NO. SV 148**

**Long Tapped Increaser**

Size	X	Weight
2 x 4 x 30	30	22.8

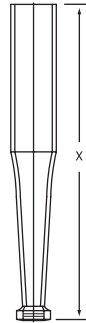

**PART NO. SV 151**

**Tapped Spigot**

Size	A	Weight
4 x 2	4 1/4	4.7

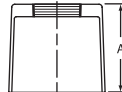

**PART NO. SV 153**

**Double Hub Fitting**

Size	X	Weight
2	1¼	4.2
3	1¼	7.0
4	1½	9.1
6	1½	13.1
8	1½	22.1
10	1½	36.3
12	1½	46.3
15	(XH)	(XH)

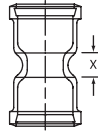

**PART NO. SV 155**

**Pipe Plug**

Size	X	Weight
2	3½	1.3
3	3¾	2.5
4	4	4.1
5	4	6.0
6	4	8.0
8	4½	12.4
10	4½	17.7
12	5¼	23.3
15	(XH)	(XH)

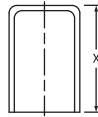

**PART NO. SV 159**

**Vent Cap with Set Screw**

Size	Weight
4	2.6



**PART NO. SV 169**

**"P" Trap**

Size	J	X	Weight
2	4	9½	7.1
3	5½	12	13.1
4	6½	14	23.2
5	7½	15½	30.4
6	8½	17	42.0
8	10½	22¼	86.2

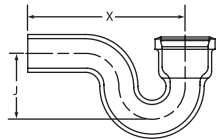

(XH) Please see Extra Heavy dimensions

**PART NO. SV 170**

**Running Trap**

Size	X	C	J	Weight
4	17½	6	6½	19.3
6	21½	8	8½	48.0

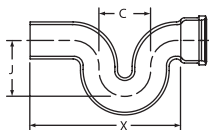

**PART NO. SV 174**

**Running Trap with Single Hub Vent**

Size	Vent Size	C	J	X	X'	Weight
3	3	5	5½	15	2½	15.3
4	4	6	6½	17½	3	28.3
5	4	7	7½	19½	3½	39.7
6	4	8	8½	21½	4	45.9
8	4	10	11	27 <sup>5</sup> / <sub>8</sub>	5¼	95.9
8	6	10	11	27 <sup>5</sup> / <sub>8</sub>	5¼	110.0

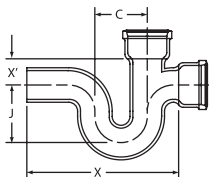

**PART NO. SV 175**

**Running Trap with Double Hub Vent**

Size	Vent Size	C	J	X	X'	Weight
3	3	5	5½	15	2½	23.0
4	4	6	6½	17½	3	36.3
5	4	7	7½	19½	3½	42.5
6	4	8	8½	21½	4	57.3
6	6	8	8½	21½	4	61.5
8	4	10	11	27 <sup>5</sup> / <sub>8</sub>	5¼	98.8
8	6	10	11	27 <sup>5</sup> / <sub>8</sub>	5¼	99.7
10	8	12	13	31 <sup>5</sup> / <sub>8</sub>	6¼	187.0
12	10	15	15	38¾	7¼	287.6
15	12	18½	18½	45	9	460.0

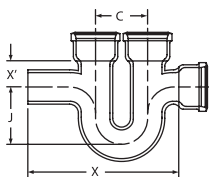

**PART NO. SV 180**

**Deep Seal "P" Trap**

Size	X	J	Weight
2	9½	6	8.1
3	12	7	14.3
4	14	8	29.0
6	17	9½	40.4

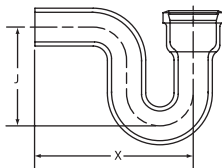

**PART NO. SV 184<sup>(T)</sup>**

**Improved Running Trap with Double Cleanout and Tee Branch**

Vent Size	Size	E	G	X	X'	Weight
4	3	5¼	6¼	20½	5½	34.3
4	4	5¾	6¼	20½	5½	33.7

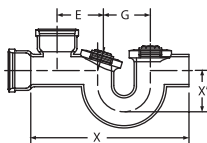

**PART NO. SV 188<sup>(T)</sup>**

**"P" Trap with Cleanout Right Side**

Size	X	J	B	D	Weight
4	14	6½	11	5½	20.0

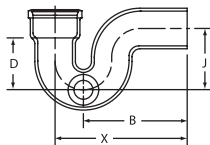

**PART NO. SV 188A<sup>(T)</sup>**

**"P" Trap with Cleanout Left Side**

Size	X	J	B	D	Weight
4	14	6½	11	5½	20.0

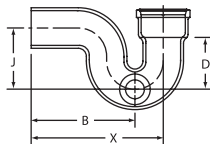

**PART NO. SV 198**

**"P" Trap with ½" Heel Tap**

Size	X	J	A	Weight
2	9½	4	4	6.8
3	12	5½	4¾	13.0
4	14	6½	4⅝	23.1

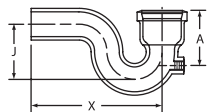

<sup>(T)</sup> Note: 3½" IPS tap

SERVICE

## PART NO. SV 200

## Closet Bend, Plain - Less Collar

Size	A	B	Weight
3 x 4	6	12	11.3
3 x 4	6	15	12.0
3 x 4	6	16	12.0
3 x 4	6	18	13.0
3 x 4	8	18	14.0
3 x 4	10	12	13.0
3 x 4	10	15	13.0
3 x 4	10	16	17.5
3 x 4	10	18	16.0
3 x 4	12	12	15.9
3 x 4	16	16	20.6
3 x 4	18	18	22.7
3	16	16	16.7
4	4	12	12.3
4	4	14	11.0
4	4	16	14.3
4	4	18	17.1
4	6	12	12.5
4	6	15	15.0
4	6	16	16.9
4	6	18	14.0
4	8	16	18.4
4	8	18	19.8
4	10	12	15.3
4	10	15	18.0
4	10	16	19.6
4	10	18	19.0
4	12	12	14.0
4	12	14	14.0
4	12	16	20.8
4	12	18	19.0
4	14	16	22.6
4	14	18	24.0
4	16	16	23.8
4	16	18	24.7
4	18	18	27.4

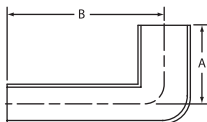

**PART NO. SV 206**

**Tapped Closet Bend with  
Southern Code Brass Plug**

Size	A	B	Weight
3 1/2 x 4 x 4 x 18	18	4	17.4

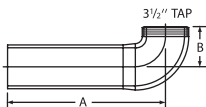

**PART NO. SV 208**

**Hub-End Closet Bend, Low Hub**

Size	A	B	Weight
4	4 5/8	12	14.2
4	4 5/8	14	15.4
4	4 5/8	16	17.5
4	4 5/8	18	18.9

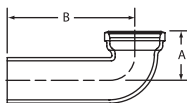

**PART NO. SPL 217**

**Offset Closet Flange (To Offset 1")**

Size	A	B	C	D	Weight
4 x 2	2	6	1	5/8	2.5
4 x 2 1/2	2 1/2	7 3/16	1	5/8	3.3
4 x 4 <sup>◇</sup>	4	6 1/4	2	2	4.5

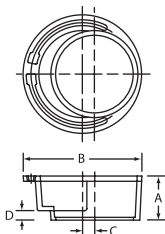

**PART NO. SPL 219**

**Greensboro  
Reducing Closet Flange  
(Can be used to connect 4" fixture  
with 3" line, or 4" No-Hub)**

Size	A	B	Weight
4 x 3 x 3	3 1/8	7 3/16	3.7

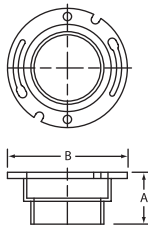

◇ 2" Offset

**PART NO. SPL 220\***

**Closest Flange, Notched and Slotted**

Size	A	B	Weight
4 x 1	1	7 <sup>3</sup> / <sub>16</sub>	2.0
4 x 1½	1½	7 <sup>3</sup> / <sub>16</sub>	2.6
4 x 2	2	7 <sup>3</sup> / <sub>16</sub>	3.0
4 x 2½	2½	7 <sup>3</sup> / <sub>16</sub>	3.6
4 x 3	3	7 <sup>3</sup> / <sub>16</sub>	4.3
4 x 4	4	7 <sup>3</sup> / <sub>16</sub>	4.7
4 x 5	5	7 <sup>3</sup> / <sub>16</sub>	4.5
4 x 6	6	7 <sup>3</sup> / <sub>16</sub>	5.3

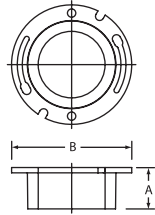

**PART NO. SPL 225**

**Instant Set Closest Flange**

Size	A	Weight
3 x 2†	2	3.5
4 x 2‡	2	5.6
4 x 3§	2	3.0
4 x 4‡	4	4.0

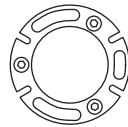
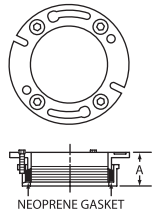

\* Caulk type to go over pipe.

† Four-bolt pattern. Test cap configuration not offered.

‡ Three-bolt pattern. Available with or without test cap.

§ Three-bolt reducing pattern, with test cap.

**PART NO. SV 228**

**Iron Body Cleanout Ferrule, Body Only,  
Less Brass Plug**

**and PART NO. SV 228S**

**Iron Body Cleanout Ferrule with Southern  
Raised-Head Brass Plug Installed †**

Size	Tap Size	A	Weight
2	1½	3½	1.3
3	2½	3¾	2.0
4	3	4¼	3.6
5	4	4¼	4.5
6	5	4¼	5.2
8	6	4½	11.7
10	6	4½	16.3
12	6	5¼	25.5
15	(XH)	(XH)	(XH)
4 x 3½	3½	4½	4.0
4 x 8	3½	8	8.1
4 x 12	3½	12	9.2

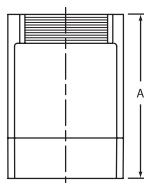
**PART NO. SV 253**

**Sission Insertable Joint**

Size	A	B	C	Weight
2	14	6	6	7.0
3	16	8	6¾	11.6
4	14½	7	6	12.9
5	15⅞	9	5⅞	17.0
6	16⅜	8½	6	20.4
8	18	10	6¾	37.0

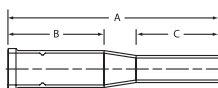
**PART NO. SV 458**

**Vented Closet Tee with 2" Top Vent  
and 2" Extended Side Inlet**

**(Right Hand or Left Hand; Designed for use  
below the floor; Fitting does not require a baffle)**

Size	A	B	C	D	E	Weight
4x4x2x2x4 RH	11	4½	5³/₁₆	4⁹/₁₆	4³/₁₆	37.0
4x4x2x2x4 LH	11	4½	5³/₁₆	4⁹/₁₆	4³/₁₆	37.8

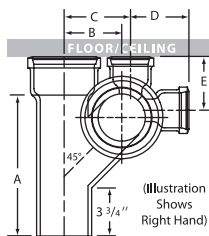

(XH) Please see Extra Heavy dimensions.

† This fitting not available with plug installed in 4 x 3½ and 4 x 8 fitting sizes.

SERVICE

**PART NO. SV 459D**

**Vented Closet Cross with 2" Top Vent  
and 2" Extended Side Inlet**  
(Designed for use below the floor;  
Fitting does not have a baffle)

Size	A	B	C	Weight
4x4x2x2x4	11	6 <sup>1</sup> / <sub>4</sub>	4 <sup>3</sup> / <sub>4</sub>	47.0

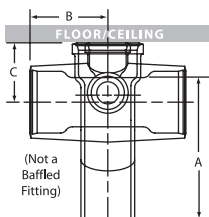

**PART NO. SV 460**

**Vented Closet Tee with 2" Top Vent**  
(Right Hand or Left Hand; Designed for use  
below the floor; Fitting does not require a baffle)

Size	A	B	C	Weight
4x4x2x4RH	11	4 <sup>1</sup> / <sub>2</sub>	5 <sup>3</sup> / <sub>16</sub>	35.0
4x4x2x4LH	11	4 <sup>1</sup> / <sub>2</sub>	5 <sup>3</sup> / <sub>16</sub>	35.0

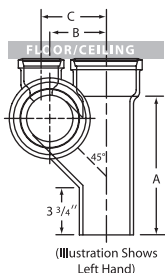

**PART NO. SV 463D**

**Vented Closet Cross with 2" Top Vent  
and 2" Extended Side Inlet**  
(Designed for use below the floor;  
Fitting does not have a baffle)

Size	A	B	C	Weight
4x4x2	11	6 <sup>1</sup> / <sub>4</sub>	4 <sup>3</sup> / <sub>4</sub>	43.8

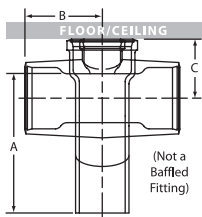

**PART NO. SV 566**

**Tapped Long Sweep Tee**

Size	A	B	C	D	Weight
2x2	5 <sup>1</sup> / <sub>2</sub>	3 <sup>1</sup> / <sub>8</sub>	4	5 <sup>5</sup> / <sub>8</sub>	6.2

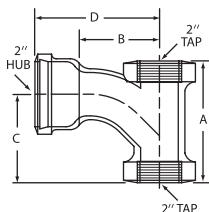

**PART NO. SV 581**

**Double Sink Stack-1770**  
**(Designed for use above the floor)**

Size	A	B	C	D	E	Weight
3 x 2 x 2	12 <sup>3</sup> / <sub>4</sub>	4 <sup>1</sup> / <sub>2</sub>	6 <sup>5</sup> / <sub>8</sub>	4 <sup>1</sup> / <sub>2</sub>	5 <sup>3</sup> / <sub>4</sub>	18.0

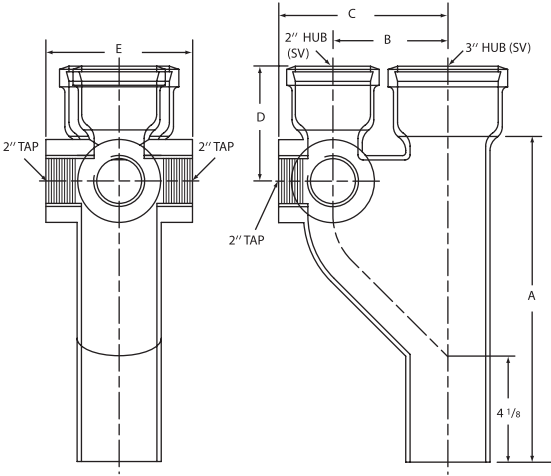

S  
E  
R  
V  
I  
C  
E

**PART NO. SV 581**

**Double Sink Stack-1770**  
**(Designed for use above the floor)**

Size	A	B	C	D	Weight
4 x 2 x 2	12 1/2	5	7 1/2	4 1/2	21.4

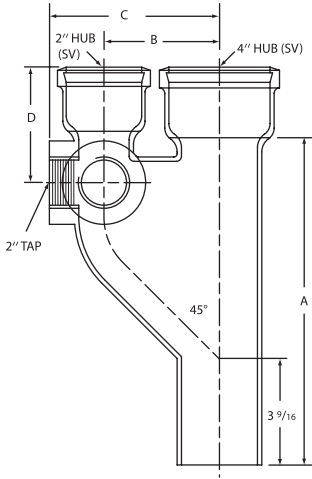

**PART NO. SV 973R**

**Right Hand Starter Fitting with 4" Tap and 2" Tapped "A" Side Inlet**  
**(Designed for use above the floor with back-outlet water closets)**

Size	Inlet	A	B	C	D	E	F	X	Weight
4	6 1/2	See Chart	6 1/2	4	4 1/16	4	4	25	34.8
4	9 1/2	See Chart	6 1/2	4	4 1/16	4	4	25	34.4

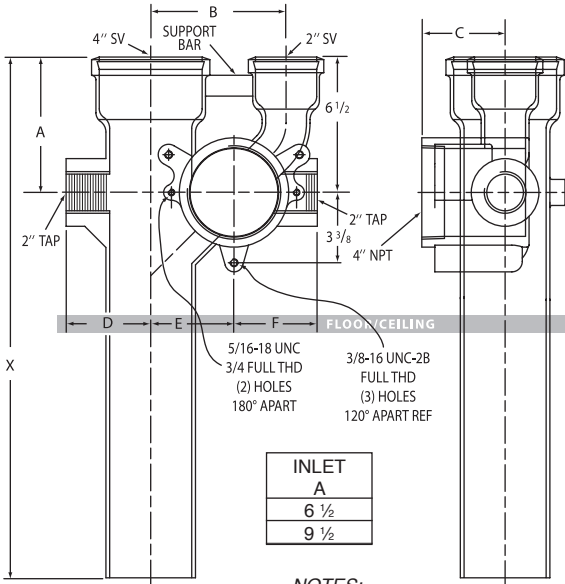

INLET
A
6 1/2
9 1/2

- NOTES:**
1. Single Vertical R.H. Offset Back Outlet Starter Fitting
  2. 4" Stack with 2" Vent & Inlets
  3. Face Plate Package Not Included

SERVICE

**PART NO. SV 973L**

**Left Hand Starter Fitting with 4" Tap and 2" Tapped "A" Side Inlet**  
**[Designed for use above the floor with back-outlet water closets]**

Size	Inlet	A	B	C	D	E	F	X	Weight
4	6 1/2	See Chart	6 1/2	4	4	4	4	25	39.2
4	9 1/2	See Chart	6 1/2	4	4	4	4	25	39.0

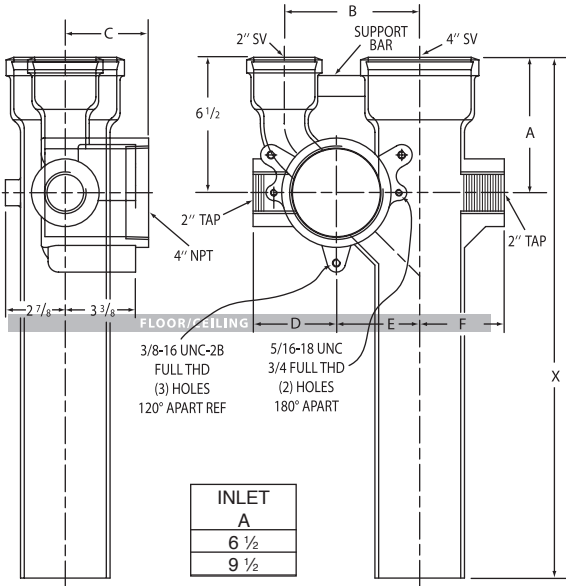

**NOTES:**

1. Single Vertical L.H. Offset Back Outlet Starter Fitting
2. 4" Stack with 2" Vent & Inlets
3. Face Plate Package Not Included

**PART NO. SV 974R**

**Right Hand Starter Fitting with 4" Hub and  
2" Tapped "A" Side Inlet**  
(Designed for use above or in the floor with back-outlet  
or bottom-outlet water closets)

Size	A	B	C	D	E	F	X	Weight
4 with A Inlet	6 1/2	6 1/2	6 1/2	4 1/16	4	4	25	39.2

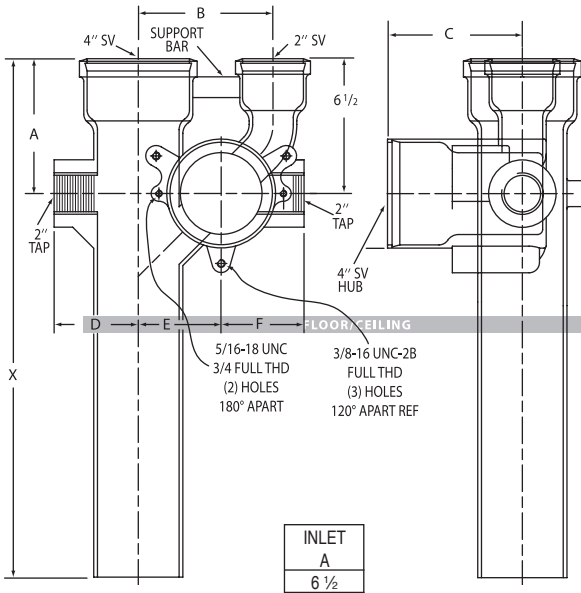

**PART NO. SV 974R**

**Right Hand Starter Fitting with 4" Hub and  
2" Tapped "A" and "B" Side Inlets**  
(Designed for use above or in the floor with back-outlet  
or bottom-outlet water closets)

Size	A	B	C	D	X	Weight
4 with A & B Inlets	6½	18	6½	6½	25	46.2

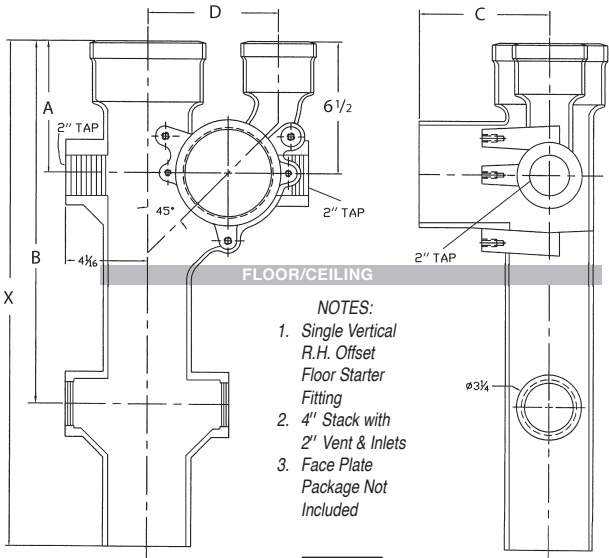

FLOOR/CEILING

**NOTES:**

1. Single Vertical R.H. Offset Floor Starter Fitting
2. 4" Stack with 2' Vent & Inlets
3. Face Plate Package Not Included

INLET	
A	B
6½	18

**PART NO. SV 974L**

**Left Hand Starter Fitting with 4" Hub and  
2" Tapped "A" Side Inlet**  
(Designed for use above or in the floor with back-outlet  
or bottom-outlet water closets)

Size	A	B	C	D	E	F	X	Weight
4 with A Inlet	6 1/2	6 1/2	6 1/2	4	4	4 1/16	25	39.7

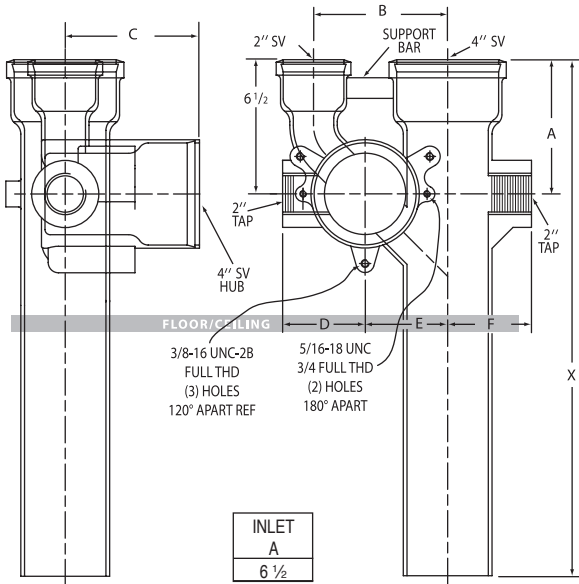

S  
E  
R  
V  
I  
C  
E

**PART NO. SV 974L**

**Left Hand Starter Fitting with 4" Hub and  
2" Tapped "A" and "B" Side Inlets  
(Designed for use above or in the floor with back-outlet  
or bottom-outlet water closets)**

Size	A	B	C	D	X	Weight
4 with A & B Inlets	6½	18	6½	6½	25	43.7

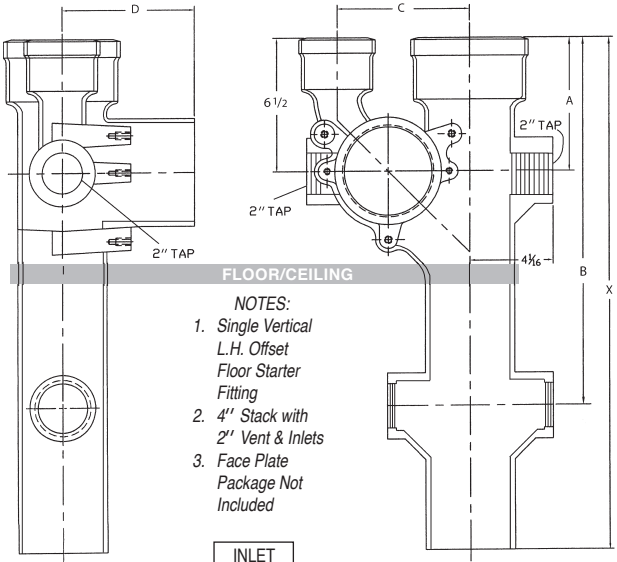

- NOTES:**
1. Single Vertical L.H. Offset Floor Starter Fitting
  2. 4" Stack with 2" Vent & Inlets
  3. Face Plate Package Not Included

INLET	
A	B
6½	18

**PART NO. SV 975**

**Double Starter Fitting with 4" Tap and  
2" Tapped "A" Side Inlet**  
[Designed for use above the floor with back-outlet  
water closets; Fitting has a baffle]

Size	A	B	C	D	E	F	X	Weight
4 with A Inlet	9 1/2	6 1/2	4	4	4	4 1/16	25	42.5

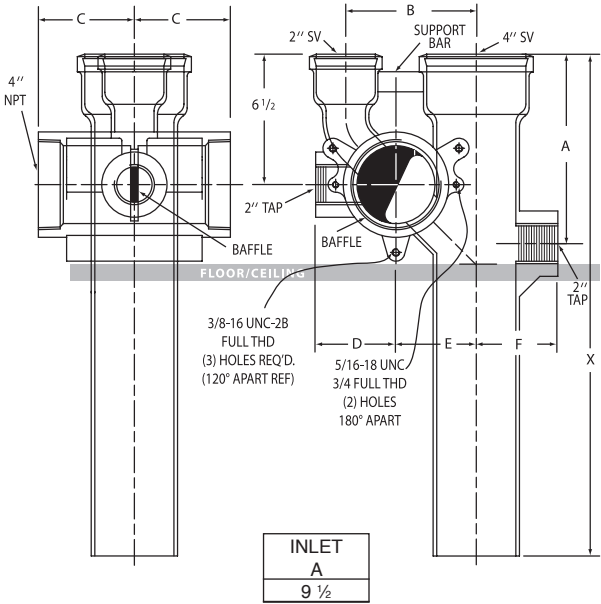

**NOTES:**

1. Double Vertical Offset Back Outlet Starter Fitting
2. 4" Stack with 2" Vent & Inlets
3. Face Plate Package Not Included

**PART NO. SV 976**

**Double Starter Fitting with 4" Hub and 2" Tapped "A" Side Inlet**  
**(Designed for use above or in the floor with back-outlet or bottom-outlet water closets; Fitting has a baffle)**

Size	A	B	C	D	E	F	X	Weight
4 with A Inlet	6 1/2	6 1/2	6 1/2	4	4	4 1/16	25	50.8

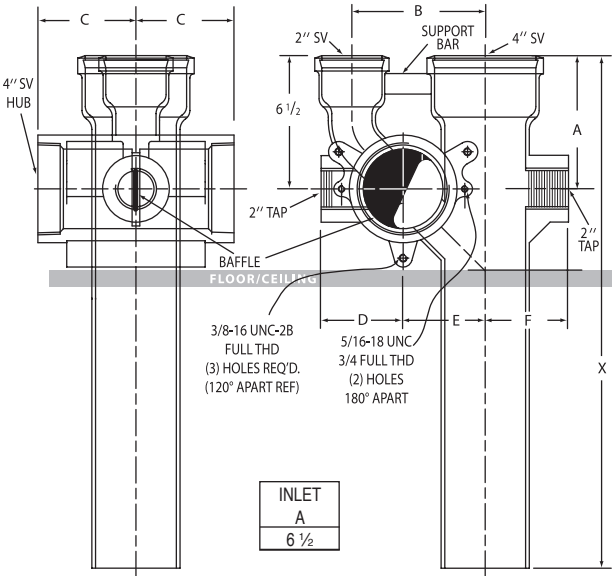

**PART NO. SV 976**

**Double Starter Fitting with 4" Hub and  
2" Tapped "A" and "B" Side Inlets**

**(Designed for use above or in the floor with back-outlet or bottom-outlet  
water closets; Fitting has a baffle)**

Size	A	B	C	D	E	X	Weight
4 with A & B Inlets	6 1/2	18	6 1/2	6 1/2	4 1/16	25	56.6

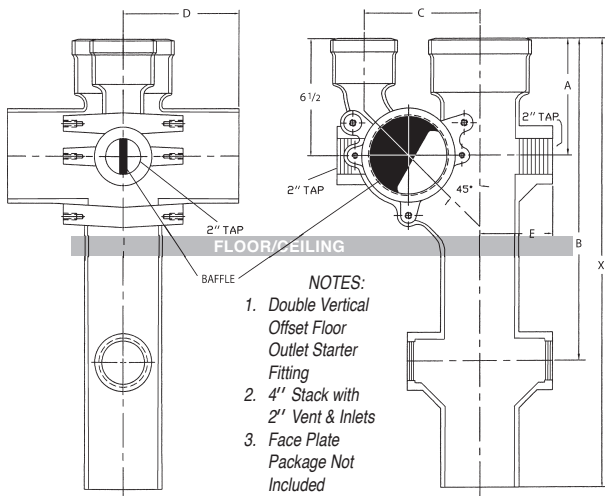

INLET	
A	B
6 1/2	18

**PART NO. SV 982**

**Tapped By-Pass Vent Fitting**

Size	A	B	C	D	E	F	Weight
2x2	18	10	6 1/2	3 1/2	3	5 1/4	11.3

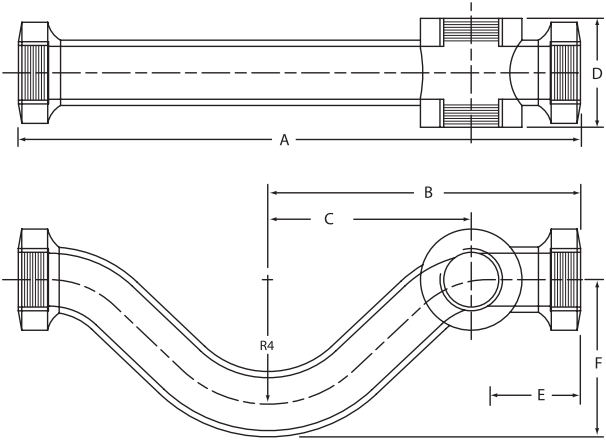

**PART NO. SV 985**

**Tapped Bath Vent Wye**

Size	A	B	C	D	Weight
2 X 2	4 1/16	5	3 1/4	2 1/2	8.4

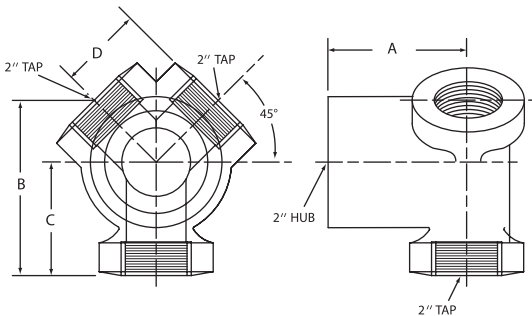



**PART NO. SV 1739L**

**Left Hand Vented Closet Tee with 2" 45° Taps**  
**(Designed for use above the floor)**

Size	A	B	C	D	E	F	G	Weight
4x2x4x2	18	6 <sup>3</sup> / <sub>4</sub>	8 <sup>1</sup> / <sub>4</sub>	4 <sup>5</sup> / <sub>8</sub>	3 <sup>5</sup> / <sub>8</sub>	4 <sup>1</sup> / <sub>2</sub>	2 <sup>3</sup> / <sub>4</sub>	51.0

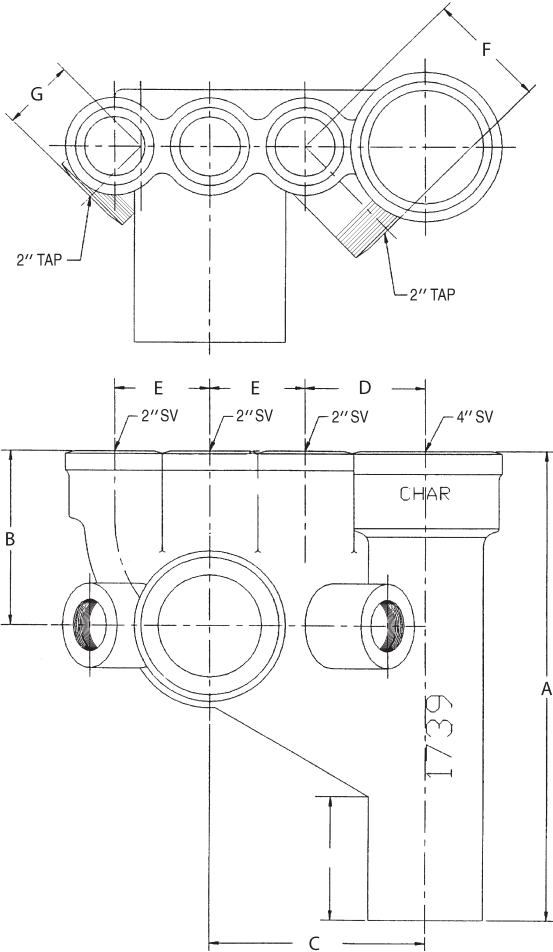

**PART NO. SV 1739 D**

**Vented Closet Cross with 2" 45° Taps**  
**(Designed for use above the floor)**

Size	A	B	C	D	E	F	G	Weight
4x2x4x2	18	6 <sup>3</sup> / <sub>4</sub>	8 <sup>1</sup> / <sub>4</sub>	4 <sup>5</sup> / <sub>8</sub>	3 <sup>5</sup> / <sub>8</sub>	4 <sup>1</sup> / <sub>2</sub>	2 <sup>3</sup> / <sub>4</sub>	57.5

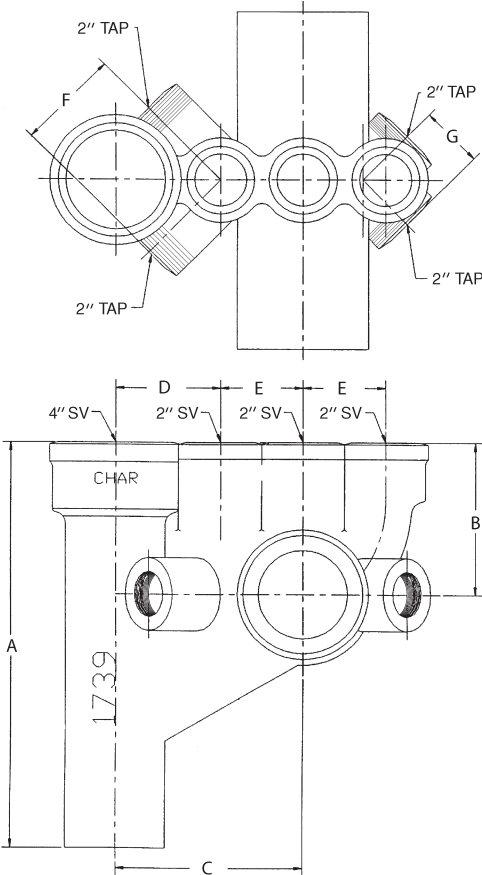

S  
E  
R  
V  
I  
C  
E

**PART NO. SV 1801**

**Tapped Harp Fitting**

Size	A	B	C	Weight
2 X 2 X 2	117/16	2	35/8	15.5

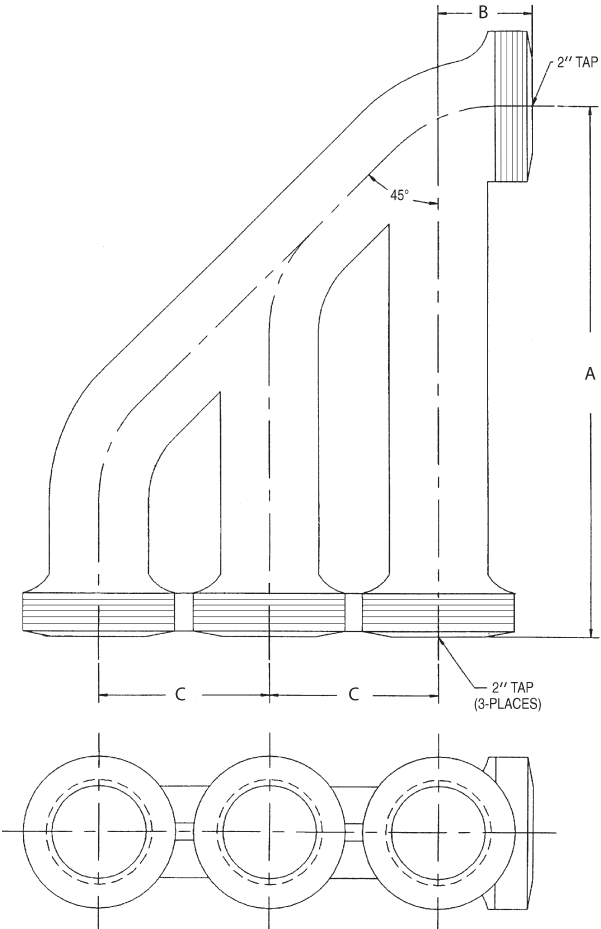

**MULTI-STORY INSTALLATION**

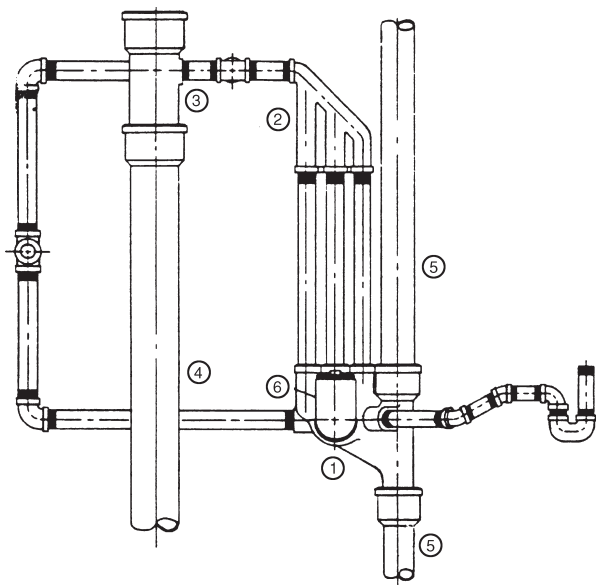

- ① SV 1739 Left Hand Vented Closet Tee with 2" 45° Taps
- ② SV 1801 2x2x2 Tapped Harp Fitting
- ③ SV 83 5x2 Straight Tapped Tee
- ④ 5x10 SV Single Hub Pipe
- ⑤ 4x10 SV Single Hub Pipe
- ⑥ SV 206 4x4x18 Tapped Closet Bend with Southern Code Brass Plug

## MULTI-STORY INSTALLATION

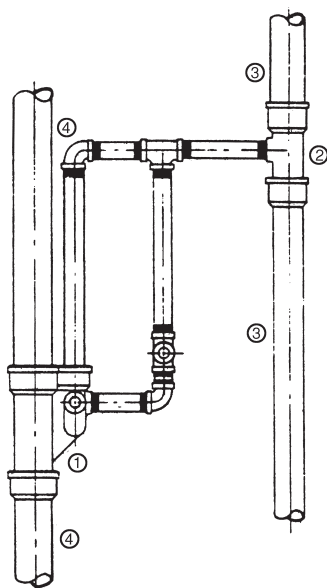

- ① SV 581 4x2x2 Double Sink Stack — 1770
- ② SV 83 3x2 Straight Tapped Tee
- ③ 3x10 Single Hub Pipe
- ④ 4x10 Single Hub Pipe

# Extra Heavy

EXTRA HEAVY

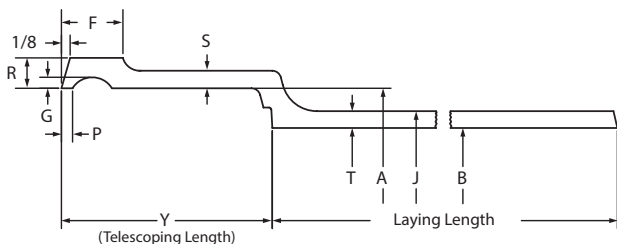

## PIPE - EXTRA-HEAVY\*

Size	Telescoping Length	Hub I.D.	Barrel		Nominal Thickness
	Y	A	J	B	T
2"	2.50	3.06	2.38	2.00	0.19
3"	2.75	4.19	3.50	3.00	0.25
4"	3.00	5.19	4.50	4.00	0.25
5"	3.00	6.19	5.50	5.00	0.25
6"	3.00	7.19	6.50	6.00	0.25
8"	3.50	9.50	8.62	8.00	0.31
10"	3.50	11.62	10.75	10.00	0.37
12"	4.25	13.75	12.75	12.00	0.37
15"	4.25	16.95	15.88	15.00	0.44

## CHARLOTTE® SPEED-PAK FIVE FOOT PIPE BUNDLES

EXTRA HEAVY WEIGHT				
	SIZE	PIECES	WEIGHT	HEIGHT
Single Hub	2"	84	2099	18"
	3"	45	1998	20"
	4"	33	1968	21"
	5"	23	1695	25"
	6"	18	1465	23"
	8"	11	1552	24"
	10"	8	1574	29"
	12"	6	1471	29"
Double Hub	15"	2	700	20"
	2"	84	2207	23"
	3"	45	2007	24"
	4"	33	1992	25"
	5"	23	1847	29"
	6"	18	1535	28"

\* For additional dimensional information please see the Cast Iron Technical and Installation Manual.

**CHARLOTTE® SPEED-PAK**  
**30" SINGLE HUB PIPE BUNDLES**

EXTRA HEAVY WEIGHT				
30" Single Hub	SIZE	PIECES	WEIGHT	HEIGHT
	8 x 30"	11	835	26"
	10 x 30"	8	901	24"
	12 x 30"	6	816	30"
	15 x 30"	2	394	19"

**TEN FOOT PIPE BUNDLES**

EXTRA HEAVY WEIGHT				
Single Hub	SIZE	PIECES	WEIGHT	HEIGHT
	2 x 10'	48	2173	12"
	3 x 10'	30	2517	15"
	4 x 10'	24	2517	18"
	5 x 10'	21	2820	20"
	6 x 10'	12	1879	16"
	8 x 10'	8	1968	21"
	10 x 10'	6	2252	25"
	12 x 10'	3	1413	15"
	15 x 10'	2	1353	20"

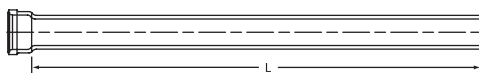
**PART NO. XH 1**

**Pipe, 5' Lengths, Single Hub**

Size	L	Weight
2" x 5'	5'	25.0
3" x 5'	5'	44.4
4" x 5'	5'	59.6
5" x 5'	5'	73.7
6" x 5'	5'	81.4
8" x 5'	5'	141.1
10" x 5'	5'	196.7
12" x 5'	5'	245.2
15" x 5'	5'	350.0

Weights are approximate and are for shipping purposes only.

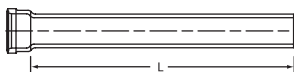
## PART NO. XH 1A



## Pipe, 30'' Lengths, Single Hub

Size	L	Weight
8'' x 30''	30''	75.9
10'' x 30''	30''	112.6
12'' x 30''	30''	136.0
15'' x 30''	30''	197.0

## PART NO. XH 2

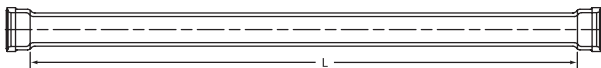

## Pipe, 5' Lengths, Double Hub

Size	L	Weight
2'' x 5'	4' 9 1/2''	26.3
3'' x 5'	4' 9 1/4''	44.6
4'' x 5'	4' 9''	60.4
5'' x 5'	4' 9''	80.3
6'' x 5'	4' 9''	85.3

## PART NO. XH 3

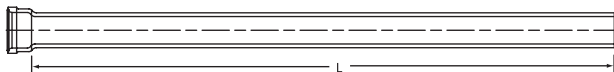

## Pipe, 10' Lengths, Single Hub

Size	L	Weight
2'' x 10'	10'	45.3
3'' x 10'	10'	83.9
4'' x 10'	10'	104.9
5'' x 10'	10'	134.3
6'' x 10'	10'	156.6
8'' x 10'	10'	246.1
10'' x 10'	10'	375.4
12'' x 10'	10'	471.0
15'' x 10'	10'	676.4

**PART NO. XH 4**



**Pipe, 30'' Lengths, Double Hub**

Size	L	Weight
2'' x 30''	25''	15.0
3'' x 30''	24 1/2''	26.0
4'' x 30''	24''	33.0

**PART NO. XH 900**

**Extra Heavy Charlotte Seal Gasket**

Size	A	D	F	G	H	Weight
2	3 1/2	2 3/8	2 9/32	3 3/16	1 7/8	0.3
3	4 15/16	3 1/2	3 1/2	4 1/2	2 1/4	0.4
4	5 3/4	4 7/32	4 13/32	5 7/16	2 1/4	0.6
5	6 3/4	5 1/2	5 1/2	6 3/16	2 1/2	0.7
6	8	6 1/2	6 1/2	7 3/8	2 1/2	0.9
8	10	8 1/2	8 5/16	9 1/2	3	1.6
10	12 1/2	10 3/4	10 1 1/32	11 1/2	3	2.0
12	14 7/16	12 5/8	12 5/8	14	3	2.8

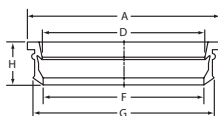

**PART NO. XH 950**

**Extra Heavy Quick-Tite Gasket**

Size	A	D	F	G	H	Weight
4	6 1/8	4 1/4	4 13/32	5 11/16	1 13/16	0.6
15	17 3/4	15 13/32	15	16 7/8	3 1/4	5.0

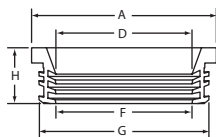

**PART NO. XH 5**

**Quarter Bend**

Size	D	X	Weight
2	6	3¼	6.3
3	7	4	11.1
4	8	4½	15.5
5	8½	5	18.5
6	9	5½	25.8
8	11½	6⅝	47.0
10	12½	7⅝	80.0
12	15	8¾	142.0
15	16½	10¼	173.9

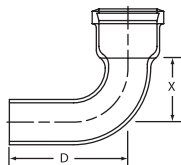

**E  
X  
T  
R  
A  
  
H  
E  
A  
V  
Y**

**PART NO. XH 7**

**Sixth Bend**

Size	D	X	Weight
2	4¾	2	6.0
3	5½	2½	7.2
4	6⅝	2⅓	14.0
6	6⅞	3⅜	21.0

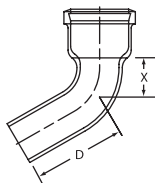

**PART NO. XH 8**

**Eighth Bend**

Size	D	X	Weight
2	4 <sup>1</sup> / <sub>4</sub>	1 <sup>1</sup> / <sub>2</sub>	4.7
3	4 <sup>15</sup> / <sub>16</sub>	1 <sup>15</sup> / <sub>16</sub>	8.8
4	5 <sup>11</sup> / <sub>16</sub>	2 <sup>3</sup> / <sub>16</sub>	12.4
5	5 <sup>7</sup> / <sub>8</sub>	2 <sup>3</sup> / <sub>8</sub>	15.0
6	6 <sup>1</sup> / <sub>16</sub>	2 <sup>9</sup> / <sub>16</sub>	18.9
8	8	3 <sup>1</sup> / <sub>8</sub>	36.2
10	8 <sup>3</sup> / <sub>8</sub>	3 <sup>1</sup> / <sub>2</sub>	59.7
12	10 <sup>5</sup> / <sub>16</sub>	4 <sup>1</sup> / <sub>16</sub>	90.0
15	10 <sup>15</sup> / <sub>16</sub>	4 <sup>11</sup> / <sub>16</sub>	122.0

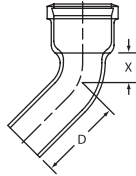

**PART NO. XH 9**

**Sixteenth Bend**

Size	D	X	Weight
2	3 <sup>5</sup> / <sub>8</sub>	7 <sup>7</sup> / <sub>8</sub>	4.6
3	4 <sup>3</sup> / <sub>16</sub>	1 <sup>3</sup> / <sub>16</sub>	9.1
4	4 <sup>13</sup> / <sub>16</sub>	1 <sup>5</sup> / <sub>16</sub>	9.5
5	4 <sup>7</sup> / <sub>8</sub>	1 <sup>3</sup> / <sub>8</sub>	13.8
6	5	1 <sup>1</sup> / <sub>2</sub>	16.0
8	6 <sup>11</sup> / <sub>16</sub>	1 <sup>13</sup> / <sub>16</sub>	31.8
10	6 <sup>7</sup> / <sub>8</sub>	2	53.0
12	8 <sup>5</sup> / <sub>8</sub>	2 <sup>3</sup> / <sub>8</sub>	65.0
15	8 <sup>7</sup> / <sub>8</sub>	2 <sup>5</sup> / <sub>8</sub>	103.0

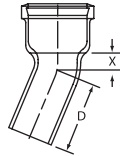

**PART NO. XH 26**

**Long Eighth Bend**

Size	D	X	Weight
4 x 18	18	2 <sup>3</sup> / <sub>16</sub>	26.0

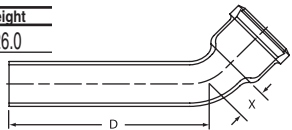

## PART NO. XH 29

## Short Sweep Bend

Size	D	X	Weight
2	8	5 $\frac{1}{4}$	7.2
3	9	6	13.0
4	10	6 $\frac{1}{2}$	18.2
5	10 $\frac{1}{2}$	7	23.8
6	11	7 $\frac{1}{2}$	28.4
8	13 $\frac{1}{2}$	8 $\frac{5}{8}$	57.0
10	14 $\frac{1}{2}$	9 $\frac{5}{8}$	90.0
12	17	10 $\frac{3}{4}$	136.0

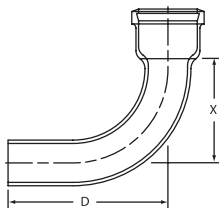
 EXTRA  
 HEAVY

## PART NO. XH 30

## Long Sweep Bend

Size	D	X	Weight
2	11	8 $\frac{1}{4}$	9.0
3	12	9	16.6
4	13	9 $\frac{1}{2}$	23.6
5	13 $\frac{1}{2}$	10	30.0
6	14	10 $\frac{1}{2}$	38.2
8	16 $\frac{1}{2}$	11 $\frac{5}{8}$	58.6
10	17 $\frac{1}{2}$	12 $\frac{5}{8}$	109.0
12	20	13 $\frac{3}{4}$	136.0
15	21 $\frac{1}{2}$	15 $\frac{1}{4}$	213.3

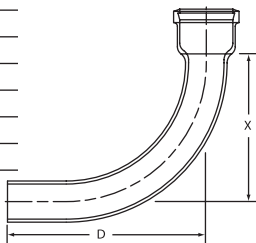

## PART NO. XH 33

**Combination Wye & Eighth Bend  
 (Long Turn Pattern)**

Size	G	H	X	X'	Weight
2 x 2	4	3 <sup>3</sup> / <sub>8</sub>	8	4 <sup>7</sup> / <sub>8</sub>	9.7
3 x 2	4 <sup>3</sup> / <sub>16</sub>	4	9	5 <sup>3</sup> / <sub>4</sub>	16.0
3 x 3	5	5 <sup>1</sup> / <sub>16</sub>	10 <sup>1</sup> / <sub>2</sub>	7	18.2
4 x 2	3 <sup>11</sup> / <sub>16</sub>	4 <sup>1</sup> / <sub>2</sub>	9	6 <sup>1</sup> / <sub>4</sub>	18.9
4 x 3	4 <sup>1</sup> / <sub>2</sub>	5 <sup>9</sup> / <sub>16</sub>	10 <sup>1</sup> / <sub>2</sub>	7 <sup>1</sup> / <sub>2</sub>	22.0
4 x 4	4 <sup>1</sup> / <sub>2</sub>	7 <sup>1</sup> / <sub>2</sub>	12	9	28.1
5 x 4	4 <sup>1</sup> / <sub>4</sub>	7 <sup>5</sup> / <sub>16</sub>	12	9 <sup>1</sup> / <sub>2</sub>	29.3
5 x 5	5 <sup>1</sup> / <sub>2</sub>	8 <sup>5</sup> / <sub>8</sub>	13 <sup>1</sup> / <sub>2</sub>	11	33.7
6 x 2	2 <sup>11</sup> / <sub>16</sub>	5 <sup>1</sup> / <sub>2</sub>	9	7 <sup>1</sup> / <sub>4</sub>	22.0
6 x 3	3 <sup>1</sup> / <sub>8</sub>	6 <sup>9</sup> / <sub>16</sub>	10 <sup>1</sup> / <sub>2</sub>	8 <sup>1</sup> / <sub>2</sub>	30.4
6 x 4	4 <sup>1</sup> / <sub>4</sub>	7 <sup>13</sup> / <sub>16</sub>	12	10	38.5
6 x 6	5 <sup>3</sup> / <sub>4</sub>	10 <sup>5</sup> / <sub>16</sub>	15	12 <sup>7</sup> / <sub>8</sub>	53.5
8 x 4	4 <sup>3</sup> / <sub>4</sub>	8 <sup>13</sup> / <sub>16</sub>	13 <sup>1</sup> / <sub>2</sub>	11	54.0
8 x 6	6 <sup>5</sup> / <sub>16</sub>	11 <sup>5</sup> / <sub>16</sub>	16 <sup>1</sup> / <sub>2</sub>	13 <sup>7</sup> / <sub>8</sub>	70.5
8 x 8	7 <sup>11</sup> / <sub>16</sub>	13 <sup>7</sup> / <sub>8</sub>	19 <sup>1</sup> / <sub>2</sub>	17	107.4

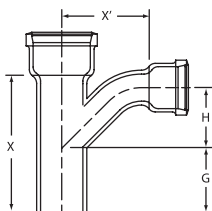

## PART NO. XH 35F

**Double Combination Wye & Eighth Bend  
 (Long Turn Pattern)**

Size	G	H	X	X'	Weight
4 x 4	5 <sup>1</sup> / <sub>4</sub>	6 <sup>13</sup> / <sub>16</sub>	12	9	44.0
6 x 4	4 <sup>1</sup> / <sub>4</sub>	7 <sup>13</sup> / <sub>16</sub>	12	10	43.0

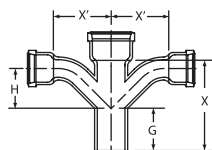

## PART NO. XH 43

## Sanitary Tee

Size	G	X	X'	Weight
2 x 2	6 <sup>1</sup> / <sub>4</sub>	8	2 <sup>7</sup> / <sub>8</sub>	8.7
3 x 2	7	9	4	14.2
3 x 3	7 <sup>1</sup> / <sub>2</sub>	10	4	17.1
4 x 2	7	9	4 <sup>1</sup> / <sub>2</sub>	17.4
4 x 3	7 <sup>1</sup> / <sub>2</sub>	10	4 <sup>1</sup> / <sub>2</sub>	18.3
4 x 4	8	11	4 <sup>1</sup> / <sub>2</sub>	22.5
5 x 5	8 <sup>1</sup> / <sub>2</sub>	12	5	28.0
6 x 3	7 <sup>1</sup> / <sub>2</sub>	10	5 <sup>1</sup> / <sub>2</sub>	24.4
6 x 4	8	11	5 <sup>1</sup> / <sub>2</sub>	28.0
6 x 6	9	13	5 <sup>1</sup> / <sub>2</sub>	35.4
8 x 4	9 <sup>3</sup> / <sub>4</sub>	13	6 <sup>1</sup> / <sub>2</sub>	51.0
8 x 6	10 <sup>3</sup> / <sub>4</sub>	15	6 <sup>1</sup> / <sub>2</sub>	54.5
8 x 8	11 <sup>3</sup> / <sub>4</sub>	17	6 <sup>5</sup> / <sub>8</sub>	72.0
10 x 6	10 <sup>3</sup> / <sub>4</sub>	15	7 <sup>1</sup> / <sub>2</sub>	77.0
10 x 8	11 <sup>3</sup> / <sub>4</sub>	17	7 <sup>5</sup> / <sub>8</sub>	95.0
10 x 10	12 <sup>3</sup> / <sub>4</sub>	19	7 <sup>5</sup> / <sub>8</sub>	115.0
12 x 8	13	18 <sup>1</sup> / <sub>2</sub>	8 <sup>5</sup> / <sub>8</sub>	126.0
12 x 12	15	22 <sup>1</sup> / <sub>2</sub>	8 <sup>3</sup> / <sub>4</sub>	173.0
15 x 8	13	18 <sup>1</sup> / <sub>2</sub>	10 <sup>1</sup> / <sub>8</sub>	180.0
15 x 15	16 <sup>1</sup> / <sub>2</sub>	25 <sup>1</sup> / <sub>2</sub>	10 <sup>1</sup> / <sub>4</sub>	280.0

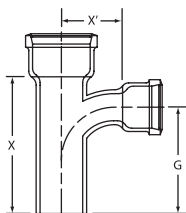

## PART NO. XH 44

Size	Wye			Weight
	G	X	X'	
2 x 2	4	8	4	9.0
3 x 2	4 <sup>3</sup> / <sub>16</sub>	9	5	13.2
3 x 3	5	10 <sup>1</sup> / <sub>2</sub>	5 <sup>1</sup> / <sub>2</sub>	17.2
4 x 2	3 <sup>5</sup> / <sub>8</sub>	9	5 <sup>3</sup> / <sub>4</sub>	16.8
4 x 3	4 <sup>7</sup> / <sub>16</sub>	10 <sup>1</sup> / <sub>2</sub>	6 <sup>1</sup> / <sub>4</sub>	20.6
4 x 4	5 <sup>1</sup> / <sub>4</sub>	12	6 <sup>3</sup> / <sub>4</sub>	23.7
5 x 3	3 <sup>7</sup> / <sub>8</sub>	10 <sup>1</sup> / <sub>2</sub>	7	23.7
5 x 4	4 <sup>11</sup> / <sub>16</sub>	12	7 <sup>1</sup> / <sub>2</sub>	28.3
5 x 5	5 <sup>1</sup> / <sub>2</sub>	13 <sup>1</sup> / <sub>2</sub>	8	31.6
6 x 3	3 <sup>3</sup> / <sub>8</sub>	10 <sup>1</sup> / <sub>2</sub>	7 <sup>3</sup> / <sub>4</sub>	26.8
6 x 4	4 <sup>3</sup> / <sub>16</sub>	12	8 <sup>1</sup> / <sub>4</sub>	31.9
6 x 5	4 <sup>15</sup> / <sub>16</sub>	13 <sup>1</sup> / <sub>2</sub>	8 <sup>3</sup> / <sub>4</sub>	33.8
6 x 6	5 <sup>3</sup> / <sub>4</sub>	15	9 <sup>1</sup> / <sub>4</sub>	41.2
8 x 4	4 <sup>3</sup> / <sub>4</sub>	13 <sup>1</sup> / <sub>2</sub>	9 <sup>1</sup> / <sub>2</sub>	50.2
8 x 6	6 <sup>5</sup> / <sub>16</sub>	16 <sup>1</sup> / <sub>2</sub>	10 <sup>1</sup> / <sub>2</sub>	61.5
8 x 8	7 <sup>11</sup> / <sub>16</sub>	19 <sup>1</sup> / <sub>2</sub>	11 <sup>13</sup> / <sub>16</sub>	86.6
10 x 4	3 <sup>9</sup> / <sub>16</sub>	13 <sup>1</sup> / <sub>2</sub>	11 <sup>1</sup> / <sub>8</sub>	72.0
10 x 6	5 <sup>1</sup> / <sub>8</sub>	16 <sup>1</sup> / <sub>2</sub>	12 <sup>1</sup> / <sub>8</sub>	84.0
10 x 8	6 <sup>1</sup> / <sub>2</sub>	19 <sup>1</sup> / <sub>2</sub>	13 <sup>7</sup> / <sub>16</sub>	101.7
10 x 10	8	22 <sup>1</sup> / <sub>2</sub>	14 <sup>1</sup> / <sub>2</sub>	137.0
12 x 6	5 <sup>11</sup> / <sub>16</sub>	18	13 <sup>7</sup> / <sub>16</sub>	108.0
12 x 8	7 <sup>1</sup> / <sub>16</sub>	21	14 <sup>3</sup> / <sub>4</sub>	140.0
12 x 10	8 <sup>9</sup> / <sub>16</sub>	24	15 <sup>13</sup> / <sub>16</sub>	180.0
12 x 12	10 <sup>1</sup> / <sub>8</sub>	27	16 <sup>7</sup> / <sub>8</sub>	198.0
15 x 4	6 <sup>7</sup> / <sub>8</sub>	15	15	153.0
15 x 8	5 <sup>3</sup> / <sub>8</sub>	21	17 <sup>1</sup> / <sub>16</sub>	219.0
15 x 10	6 <sup>7</sup> / <sub>8</sub>	24	18 <sup>1</sup> / <sub>8</sub>	229.0
15 x 12	8 <sup>7</sup> / <sub>16</sub>	27	19 <sup>9</sup> / <sub>16</sub>	236.0
15 x 15	10 <sup>3</sup> / <sub>4</sub>	31 <sup>1</sup> / <sub>2</sub>	20 <sup>3</sup> / <sub>4</sub>	309.4

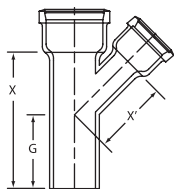

## PART NO. XH 79

## Washington Test Tee

Size	IPS		E'	G	X	Weight
	Tap					
3	4		2 <sup>7</sup> / <sub>8</sub>	7 <sup>1</sup> / <sub>8</sub>	10 <sup>3</sup> / <sub>4</sub>	13.9
4	4		3 <sup>1</sup> / <sub>4</sub>	7 <sup>1</sup> / <sub>4</sub>	10 <sup>5</sup> / <sub>8</sub>	19.9
5	5		3 <sup>5</sup> / <sub>8</sub>	7	11	24.4
6	6		4	8 <sup>3</sup> / <sub>4</sub>	13	42.2
8	8		5	11	16 <sup>3</sup> / <sub>8</sub>	58.5

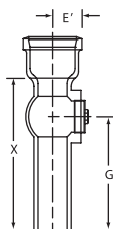

## PART NO. XH 80

## Cleanout Tee with Brass Plug

Size	IPS		E'	G	X	Weight
	Tap					
3	2		2 <sup>1</sup> / <sub>2</sub>	7	9	11.3
4	3		3	8	11	15.5
5	4		3 <sup>1</sup> / <sub>2</sub>	8 <sup>1</sup> / <sub>2</sub>	12	22.9
6	4		4 <sup>1</sup> / <sub>4</sub>	9	13	26.9

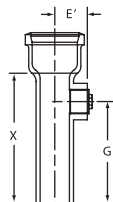

## PART NO. XH 81S

## Miami Test Tee

Size	IPS		E'	G	X	Weight
	Tap					
4	4		3	7 <sup>1</sup> / <sub>4</sub>	11	16.0

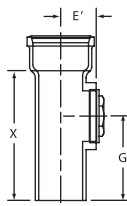

## PART NO. XH 84

## Sanitary Tapped Tee

Size	E'	G	X	Weight
4 X 2	4 <sup>1</sup> / <sub>16</sub>	7	9	14.3

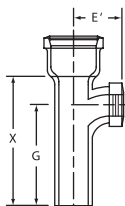

## PART NO. XH 85

## Tapped Wye

Size	G	X	X'	Weight
4 X 2	4 <sup>1</sup> / <sub>4</sub>	9	6	13.8

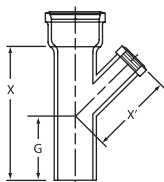

## PART NO. XH 109

## Sanitary Cross

Size	G	X	X'	Weight
4	8	11	4 <sup>1</sup> / <sub>2</sub>	27.0

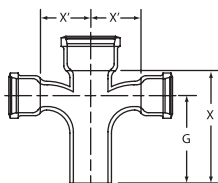

**PART NO. XH 110**

**Double Wye**

Size	G	X	X'	Weight
2	4	8	4	13.1
4 x 3	4 <sup>7</sup> / <sub>16</sub>	10 <sup>1</sup> / <sub>2</sub>	6 <sup>1</sup> / <sub>4</sub>	26.9
4	5 <sup>1</sup> / <sub>4</sub>	12	6 <sup>3</sup> / <sub>4</sub>	28.2
6 x 4	4 <sup>3</sup> / <sub>16</sub>	12	8 <sup>1</sup> / <sub>4</sub>	39.8
6	5 <sup>3</sup> / <sub>4</sub>	15	9 <sup>1</sup> / <sub>4</sub>	45.0
8	7 <sup>1</sup> / <sub>16</sub>	19 <sup>1</sup> / <sub>2</sub>	11 <sup>13</sup> / <sub>16</sub>	119.0
10	8	22 <sup>1</sup> / <sub>2</sub>	14 <sup>1</sup> / <sub>2</sub>	182.0
12	10 <sup>1</sup> / <sub>8</sub>	27	16 <sup>7</sup> / <sub>8</sub>	295.0
15	10 <sup>3</sup> / <sub>4</sub>	31 <sup>1</sup> / <sub>2</sub>	22	384.8

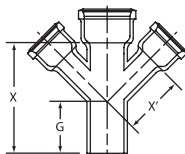

EXTRA HEAVY

**PART NO. XH 143**

**Reducer**

Size	X	Weight
3 x 2	4 <sup>3</sup> / <sub>4</sub>	6.0
4 x 2	5	7.0
4 x 3	5	8.9
5 x 3	5	11.0
5 x 4	5	11.0
6 x 3	5	12.0
6 x 4	5	12.2
6 x 5	5	12.6
8 x 4	6	19.1
8 x 5	6	19.5
8 x 6	6	19.0
10 x 4	6	28.0
10 x 6	6	30.0
10 x 8	6	35.0
12 x 4	6 <sup>1</sup> / <sub>2</sub>	36.8
12 x 6	6 <sup>1</sup> / <sub>2</sub>	46.0
12 x 8	6 <sup>1</sup> / <sub>2</sub>	43.0
12 x 10	6 <sup>1</sup> / <sub>2</sub>	50.0
15 x 8	6 <sup>1</sup> / <sub>2</sub>	55.5
15 x 10	6 <sup>1</sup> / <sub>2</sub>	57.0
15 x 12	6 <sup>1</sup> / <sub>2</sub>	62.0

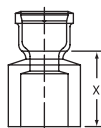

## PART NO. XH 144

## Reducer In creaser

Size	X	Weight
4 x 6	9	15.8
6 x 8	12	33.8

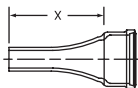

## PART NO. XH 153

## Double Hub Fitting

Size	X	Weight
2	1 1/4	5.0
4	1 1/2	9.4
5	1 1/2	12.0
6	1 1/2	14.0
8	1 1/2	28.0
10	1 1/2	43.0
12	1 1/2	54.0
15	1 1/2	80.0

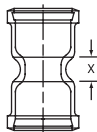

## PART NO. XH 155

## Pipe Plug

Size	X	Weight
2	3 1/2	1.4
4	4	4.7
6	4	8.0
8	4 1/2	15.0
10	4 1/2	29.0
12	5 1/4	32.0
15	5 1/4	44.0

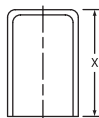

## PART NO. XH 169

## "P" Trap

Size	J	X	Weight
2	4	9½	7.9
3	5½	12	17.2
4	6½	14	27.2
6	8½	17	45.2
8	10½	22½	120.0

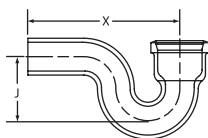

## PART NO. XH 174

## Running Trap with Single Hub Vent

Size	Vent		J	X	X'	Weight
	Size	C				
3	3	5	5½	15	2½	22.8
4	4	6	6½	17½	3	35.6
5	4	7	7½	19½	3½	46.0
6	4	8	8½	21½	4	59.0

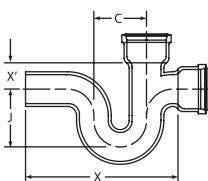

## PART NO. XH 175

Running Trap  
with Double Hub Vent

Size	Vent		J	X	X'	Weight
	Size	C				
3	3	5	5½	15	2½	30.0
4	4	6	6½	17½	3	37.4
5	4	7	7½	19½	3½	50.0
6	4	8	8½	21½	4	65.5
6	6	8	8½	21½	4	71.0
8	4	10	11	27⅝	5¼	127.0
8	6	10	11	27⅝	5¼	119.6
10	8	12	13	31⅝	6¼	193.0
12	6	15	15	38¾	7¼	274.0

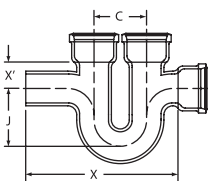

**PART NO. XH 180**

**Deep Seal "P" Trap**

Size	X	J	Weight
2	9½	6	9.8
3	12	7	20.3
4	14	8	29.0

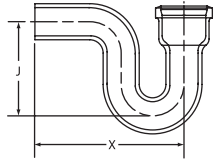

**PART NO. XH 184<sup>(T)</sup>**

**Improved Running Trap with Double Cleanout and Tee Branch**

Size	Vent Size	E	G	X	X'	Weight
4	3	5¼	6¼	20½	5½	41.8
4	4	5¾	6¼	20½	5½	42.9

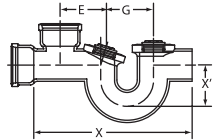

**PART NO. XH 198**

**"P" Trap with ½" Heel Tap**

Size	X	J	A	Weight
2	9½	4	4	9.0
3	12	5½	4¾	17.0
4	14	6½	4⅝	27.0

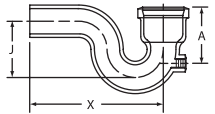

<sup>(T)</sup> Note: 3½" IPS tap

## PART NO. XH 230

**Iron Body Cleanout,  
 Body Only, Less Brass Plug**

Size	Tap Size	A	Weight
2 <sup>(S)</sup>	1½	3½	1.7
3 <sup>(S)</sup>	2½	3¾	3.2
4	3½	4¼	4.3
5 <sup>(S)</sup>	4	4¼	6.5
6	5	4¼	6.6
8	6	4½	13.1
10	6	4½	21.0
12	6	5¼	38.0
15	6	5¼	52.8

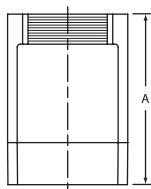
 EXTRA  
 HEAVY

## PART NO. XH 253

**Sission Insertable Joint**

Size	A	B	C	Weight
4	14½	7	6	17.1
6	16 <sup>3</sup> / <sub>16</sub>	8½	6	26.2

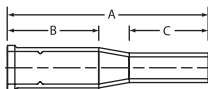

## PART NO. XH 549

**Roof Iron**

Size	A	B	C	D	E	Weight
4	10 <sup>7</sup> / <sub>16</sub>	5 <sup>3</sup> / <sub>8</sub>	4 <sup>13</sup> / <sub>16</sub>	3 <sup>3</sup> / <sub>16</sub>	2½	8.2

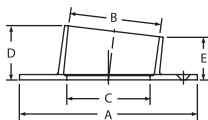

<sup>(S)</sup> Size available only with Southern Raised-Head Brass Plug installed

# Plugs

## PART NO. PLG 410

### Ohio Code Brass Plug

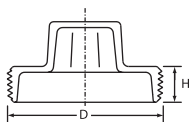
Size	D	H	Weight
10	$10^{23/32}$	$2^{1/32}$	10.6



## PART NO. PLG 430

### Southern Code Brass Plug

Size	D	H	Weight
1 1/2	$1^{57/64}$	$49/64$	0.2
2	$2^{23/64}$	$49/64$	0.3
2 1/2	$2^{55/64}$	$51/64$	0.4
3	$3^{15/32}$	$57/64$	0.6
3 1/2	$3^{63/64}$	$57/64$	0.7
4	$4^{31/64}$	$61/64$	1.1
5	$5^{35/64}$	$61/64$	1.5
6	$6^{19/32}$	$17/32$	2.5
8	$8^{39/64}$	$19/32$	4.0

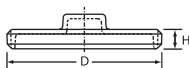

## PART NO. PLG 440

### Southern Code Countersunk Brass Plug

Size	D	H	Weight
1 1/2	$1^{57/64}$	$13/32$	0.2
2	$2^{23/64}$	$7/16$	0.3
3	$3^{15/32}$	$33/64$	0.6
3 1/2	$3^{63/64}$	$33/64$	0.8
4	$4^{31/64}$	$35/64$	0.9
5	$5^{35/64}$	$11/16$	1.7
6	$6^{19/32}$	$11/16$	2.3

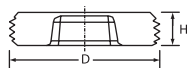

## PART NO. PLG 450

### Cast Iron Plug

Size	D	H	Weight
6	$6^{35/64}$	$1^{17/64}$	4.2
10	$10^{39/64}$	$1^{31/32}$	9.0

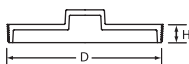

# CHARLOTTE

## PIPE AND FOUNDRY COMPANY

P.O. Box 35430 • Charlotte, North Carolina 28235  
704/348-6450 • 800/572-4199 • FAX 800/553-1605  
Literature By Fax 800/745-9382  
www.charlottepipe.com

This is to verify that products manufactured by Charlotte Pipe and Foundry, Cast Iron Division, are manufactured in the United States and conform to the following standards:

### **SERVICE HUB AND SPIGOT PIPE AND FITTINGS**

All cast iron soil pipe and fittings shall be marked with the collective trademark of the Cast Iron Soil Pipe Institute (CISPI).

ASTM A 74

ANSI A 112.5.1

Listed by NSF® International

ISO 9001:2008 Certified

### **EXTRA HEAVY HUB AND SPIGOT PIPE AND FITTINGS**

All cast iron soil pipe and fittings shall be marked with the collective trademark of the Cast Iron Soil Pipe Institute (CISPI).

ASTM A 74

ANSI A 112.5.1

Listed by NSF® International

ISO 9001:2008 Certified

### **HUBLESS PIPE AND FITTINGS**

All cast iron soil pipe and fittings shall be marked with the collective trademark of the Cast Iron Soil Pipe Institute (CISPI).

CISPI Standard 301

ASTM A 888

Listed by NSF® International

ISO 9001:2008 Certified

### **HUBLESS COUPLINGS**

CISPI Standard 310

ASTM C 1277

Certified by NSF® International

### **HUBLESS HEAVY DUTY COUPLINGS**

Meets ASTM C 1540

### **COMPRESSION GASKETS**

ASTM C 564

CISPI HSN 85



This catalog accurately reflects dimensional information to the best of our knowledge. If dimensions on your job are critical, please verify dimensional information with our factory.

This dimensional catalog accurately reflects our product line at the time the catalog was printed. However, we add and delete items on an ongoing basis to better serve our customers. Please refer to our current list price sheets for an accurate listing of items offered.

Charlotte Pipe® products are manufactured to the applicable ASTM standard. Charlotte Pipe and Foundry cannot accept responsibility for the performance, dimensional accuracy, or compatibility of pipe, fittings, gaskets, or couplings not manufactured or sold by Charlotte Pipe and Foundry.

# LIMITED WARRANTY

Charlotte Pipe and Foundry Company® (Charlotte Pipe®) Products are warranted to be free from manufacturing defects and to conform to currently applicable ASTM standards for a period of five (5) years from date of delivery. Buyer's remedy for breach of this warranty is limited to replacement of, or credit for, the defective product. This warranty excludes any expense for removal or reinstallation of any defective product and any other incidental, consequential, or punitive damages. **This limited warranty is the only warranty made by seller and is expressly in lieu of all other warranties, express and implied, including any warranties of merchantability and fitness for a particular purpose.** No statement, conduct or description by Charlotte Pipe or its representative, in addition to or beyond this Limited Warranty, shall constitute a warranty. This Limited Warranty may only be modified in writing signed by an officer of Charlotte Pipe.

This Limited Warranty will not apply if:

- 1) The Products are used for purposes other than their intended purpose as defined by local plumbing and building codes, and the applicable ASTM standard.
- 2) The Products are not installed in good and workmanlike manner consistent with normal industry standards; installed in compliance with the latest instructions published by Charlotte Pipe and good plumbing practices; and installed in conformance with all applicable plumbing, fire and building code requirements.
- 3) This limited warranty does not apply when the products of Charlotte Pipe are used with the products of other manufacturers that do not meet the applicable ASTM or CISPI standards or that are not marked in a manner to indicate the entity that manufactured them.
- 4) In hubless cast iron installations, this warranty will not apply if products are joined with unshielded hubless couplings. Charlotte Pipe requires that its hubless cast iron pipe and fittings be joined only with shielded hubless couplings manufactured in accordance with CISPI 310, ASTM C 1277 and certified by NSF® International or with Heavy Duty Couplings meeting ASTM C 1540.
- 5) The Products fail due to defects or deficiencies in design, engineering, or installation of the piping system of which they are a part.
- 6) The Products have been the subject of modification; misuse; misapplication; improper maintenance or repair; damage caused by the fault or negligence of anyone other than Charlotte Pipe; or any other act or event beyond the control of Charlotte Pipe.
- 7) The Products fail due to the freezing of water in the Products.
- 8) The Products fail due to contact with chemical agents, fire stopping materials, thread sealant, plasticized vinyl products, or other aggressive chemical agents that are not compatible.
- 9) Pipe outlets, sound attenuation systems or other devices are permanently attached to the surface of Charlotte® PVC, ABS or CPVC products with solvent cement or adhesive glue.

Charlotte Pipe products are manufactured to the applicable ASTM or CISPI standard. Charlotte Pipe and Foundry **cannot** accept responsibility for the performance, dimensional accuracy, or compatibility of pipe, fittings, gaskets, or couplings not manufactured or sold by Charlotte Pipe and Foundry.

Any Charlotte Pipe products alleged to be defective **must** be made available to Charlotte Pipe at the following address for verification, inspection and determination of cause:

Charlotte Pipe and Foundry Company  
Attention: Technical Services  
2109 Randolph Road  
Charlotte, North Carolina 28207

**Purchaser must obtain a return materials authorization** and instructions for return shipment to Charlotte Pipe of any product claimed defective or shipped in error.

Any Charlotte Pipe product **proved** to be defective in manufacture will be replaced F.O.B. point of original delivery, or credit will be issued, at the discretion of Charlotte Pipe.

4/24/15

## WARNING

Testing with or use of compressed air or gas in PVC / ABS / CPVC / Cast Iron pipe or fittings can result in explosive failures and cause severe injury or death.

AIR/GAS



- NEVER test with or transport/store compressed air or gas in PVC / ABS / CPVC / Cast Iron pipe or fittings.
- NEVER test PVC / ABS / CPVC / Cast Iron pipe or fittings with compressed air or gas, or air over water boosters.
- ONLY use PVC / ABS / CPVC / Cast Iron pipe or fittings for water or approved chemicals.
- Refer to warnings on PPFA's website and ASTM D 1785.

Charlotte and Charlotte Pipe are registered trademarks of Charlotte Pipe and Foundry Company.

# CHARLOTTE

PIPE AND FOUNDRY COMPANY

PO BOX 35430

CHARLOTTE

NORTH CAROLINA 28235

PHONE (704) 348-6450

(800) 438-6091

FAX (800) 553-1605

LITERATURE BY FAX (800) 745-9382

[WWW.CHARLOTTEPIPE.COM](http://WWW.CHARLOTTEPIPE.COM)



# SUBMITTAL FOR CHARLOTTE PIPE® SERVICE CAST IRON SOIL PIPE AND FITTINGS

Date: \_\_\_\_\_

Job Name: \_\_\_\_\_

Location: \_\_\_\_\_

Engineer: \_\_\_\_\_

Contractor: \_\_\_\_\_

**► Scope:**

This specification covers Service Cast Iron pipe, fittings, and compression gaskets used in sanitary drain, waste and vent (DWV), sewer, and storm drainage applications. This system is intended for use in non-pressure applications.

**► Specification:**

Pipe and fittings shall comply with ASTM A 74. Compression gaskets shall comply with ASTM C 564. All pipe and fitting shall be made in the United States, and marked with the collective trademark of the Cast Iron Soil Pipe Institute, ©. Service cast iron pipe and fittings are listed by NSF® International to the UP Code.

**► Installation:**

Installation shall comply with the latest installation instructions published by Charlotte Pipe and Foundry Company® and shall conform to all applicable plumbing, fire, and building code requirements. The system shall be hydrostatically tested after installation to 10 ft. of head (4.3 psi maximum).

**WARNING!** Never test with or transport/store compressed air or gas in Cast Iron pipe or fittings. Doing so can result in explosive failures and cause severe injury or death.

**► Referenced Standards:**

ASTM A 74: Cast Iron Soil Pipe and Fittings

ASTM C 564: Rubber Gaskets for Cast Iron Soil Pipe and Fittings



*Not all fitting patterns shown*

Size	PIPE - SERVICE				
	Telescoping Length Y	Hub I.D. A	O.D. J	Barrel I.D. B	Nominal Thickness T
2"	2.50	2.94	2.30	1.96	0.17
3"	2.75	3.94	3.30	2.96	0.17
4"	3.00	4.94	4.30	3.94	0.18
5"	3.00	5.94	5.30	4.94	0.18
6"	3.00	6.94	6.30	5.94	0.18
8"	3.50	9.25	8.38	7.94	0.23
10"	3.50	11.38	10.50	9.94	0.28
12"	4.24	13.50	12.50	11.94	0.28
15"	4.25	16.95	15.88	15.16	0.36

# SUBMITTAL FOR CHARLOTTE PIPE® HUBLESS CAST IRON SOIL PIPE AND FITTINGS

Date: \_\_\_\_\_

Job Name: \_\_\_\_\_

Location: \_\_\_\_\_

Engineer: \_\_\_\_\_

Contractor: \_\_\_\_\_

**► Scope:**

This specification covers Hubless Cast Iron pipe, fittings, and couplings used in sanitary drain, waste and vent (DWV), sewer, and storm drainage applications. This system is intended for use in non-pressure applications.

**► Specification:**

Hubless Cast Iron pipe and fittings shall be manufactured from gray cast iron and shall conform to ASTM A 888 and CISPI Standard 301. All pipe and fittings shall be marked with the collective trademark of the Cast Iron Soil Pipe Institute®  and listed by NSF® International. Hubless Couplings shall conform to CISPI Standard 310, shall be manufactured in the United States, and be certified by NSF® International. Heavy Duty couplings shall conform to ASTM C 1540, shall be manufactured in the United States, and shall be used if indicated.







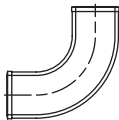

**► Installation:**

Installation shall comply with the latest installation instructions published by Charlotte Pipe and Foundry Company® and shall conform to all applicable plumbing, fire, and building code requirements. The system shall be hydrostatically tested after installation to 10 ft. of head (4.3 psi maximum). **WARNING!** Never test with or transport/store compressed air or gas in Cast Iron pipe or fittings. Doing so can result in explosive failures and cause severe injury or death.

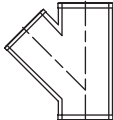
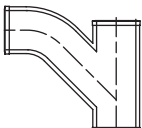
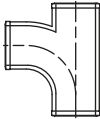
**► Referenced Standards:**

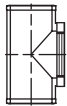
- ASTM C 564: Rubber Gaskets for Cast Iron Soil Pipe and Fittings
- CISPI 301: Hubless Cast Iron Soil Pipe and Fittings
- CISPI 310: Hubless Couplings for Cast Iron Soil Pipe and Fittings
- ASTM C 1277: Hubless Couplings
- ASTM C 1540: Hubless Heavy Duty Couplings

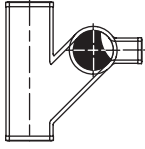
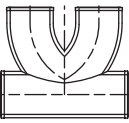

			
1/4 Bend	1/8 Bend	Wye	Combination
			
San Tee	San Cross	Test Tee	Reducer
			
"P" Trap	Blind Plug	Figure Eight	Two-Way Cleanout
<b>Not all fitting patterns shown</b>			

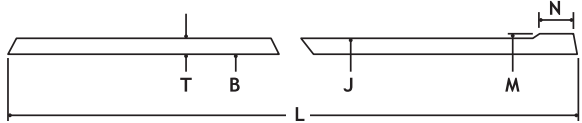

**TABLE 1**  
DIMENSIONS AND TOLERANCES (IN INCHES) OF SPIGOTS  
AND BARRELS FOR NO-HUB PIPE AND FITTINGS

Size	Inside Barrel Diameter	Outside Diameter Barrel	Outside Diameter Spigot	Width Spigot Bead N	Thickness of Barrel		Gasket Positioning Lug
	B	J	M	(± .13)	T-Nom.	T-Min.	W
1 1/2	1.50 ± .09	1.90 ± .06	1.96 ± .06	.25	.16	.13	1.13
2	1.96 ± .09	2.35 ± .09	2.41 ± .09	.25	.16	.13	1.13
3	2.96 ± .09	3.35 ± .09	3.41 ± .09	.25	.16	.13	1.13
4	3.94 ± .09	4.38 ± .09	4.44 ± .09	.31	.19	.15	1.13
5	4.94 ± .09	5.30 ± .09	5.36 ± .09	.31	.19	.15	1.50
6	5.94 ± .09	6.30 ± .09	6.36 ± .09	.31	.19	.15	1.50
8	7.94 ± .13	8.38 ± .09	8.44 ± .09	.31	.23	.17	2.00
10	10.00 ± .13	10.56 ± .09	10.62 ± .09	.31	.28	.22	2.00
12	11.94 ± .09	12.50 ± .13	12.62 ± .13	.31	.28	.22	2.75
15	15.11 ± .09	15.83 ± .13	16.12 ± .13	.31	.36	.30	2.75

**Note:** Charlotte Pipe does not recommend or warrant installations joined with unshielded hubless couplings.

Charlotte Pipe and Foundry Company • P.O. Box 35430 Charlotte, NC 28235 • (800) 438-6091 • [www.charlottepipe.com](http://www.charlottepipe.com)

Charlotte Pipe and Charlotte Pipe and Foundry Company are registered trademarks of Charlotte Pipe and Foundry Company.



Mueller Streamline Co.  
8285 Tournament Drive, Suite 150  
Memphis, TN 38125  
P 901.753.3200

Date: June 5, 2014  
Subject: **Product Standards - Copper Fittings**

Mueller Fittings Co. Inc. manufactures or supplies product which are manufactured to meet the following specifications.

#### STANDARDS:

- ASME B16.22: Wrought Copper and Copper Alloy Solder Joint Pressure Fittings
- MSS SP-104: Wrought Copper Solder Joint Pressure Fittings
- ASME B16.29: Wrought Copper and Wrought Copper Alloy Solder Joint Drainage Fittings - DWV
- ASME/ANSI B16.18: Cast Copper Alloy Solder Joint Pressure Fittings
- ASME/ANSI B16.15: Cast Bronze Threaded Fittings
- ASME/ANSI B16.23: Cast Copper Alloy Solder Joint Drainage Fittings DWV
- ASME/ANSI B16.26: Cast Copper Alloy Fittings for Flared Copper Tube
- NSF/ANSI 61-G: Drinking Water System Components
- MSS SP-106: Class 150-Cast Copper Flanges shall meet the requirements of MSS SP-106 and/or the workmanship and dimensional of Federal Spec. VVV-F-406 ASME B16.24.
- MSS SP – 106: Class 125 Bronze Pipe Flanges and Flanged Fittings
- MSS SP – 109: Welded Fabricated Copper Solder Joint Pressure Fittings
- MSS SP - 123: Threaded and Solder Joint Copper Unions

The materials used to manufacture these fittings are also in compliance with the following specifications:

#### Products Made From Sheet:

- ASTM B152 Alloy C11000: Standard Specification for Copper Sheet, Strip, Plated Rolled Bar Cast Products
- ASTM B584 Alloy C84400: Standard Specification for Copper Alloy Sand Castings
  - Or Alloy C87850: General Applications: Federal Specification WW-U-516
  - Or Alloy C87600: Type III, Class A and B Copper Alloy Unions
  - Or Alloy C89836: General Applications

#### Copper Fittings:

- ASTM B75 Alloy C12200: Standard Specification for Seamless Round, Copper Tube\*
  - Or Alloy C10200: General Engineering applications

\*NSF 61 Restriction Statement: "Copper Tube (Alloy C12200) is certified by NSF to ANSI/NSF Standard 61 for public water supplies meeting or in the process of meeting the U.S. EPA Lead and Copper Rule (56FR 26460, June 7, 1991). Water supplies with pH less than 6.5 may require corrosion control to limit copper solubility in drinking water."

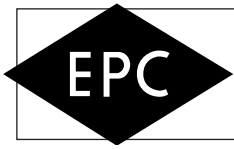

## Engineering Data

Working Pressures and Solder .....	Page 39
Estimated Qty. of 50-50 Solder Required to Make 100 Joints.....	Page 39
Wrot Copper and Bronze Solder-Joint Pressure Fittings .....	Page 39
Wrot Copper Solder-Joint Drainage Fittings .....	Page 40
Wrot Copper Fittings Large Diameter Welded Design .....	Page 40
Copper Water Tube-Standard Dimensions and Weights .....	Page 40
Copper Water Tube-Calculated Bursting Pressure* .....	Page 41
Sizes of Copper Tube Fittings .....	Page 41
Soldering and Brazing Copper Tube .....	Pages 41-42
Rated Internal Working Pressures for	
Copper Tube Types K, L, M, and DWV .....	Pages 43-44
Fractional Inch/Decimal Inch/Millimeter Conversion Chart .....	Page 44

## Product Certification

Elkhart Products Corporation manufactures and/or supplies products which meet the following specifications:

MSS	SP104-1995	<i>Wrought Copper Solder Joint Pressure Fittings</i>
ASME	B16.29-1994	<i>Wrought Copper and Wrought Copper Alloy Solder Joint Drainage Fittings - DWV</i>
ASME	B16.18-1994	<i>Cast Copper Alloy Solder Joint Pressure Fittings</i>
ASME	B16.15-1994	<i>Cast Bronze Threaded Fittings</i>
ASME	B16.26-1988	<i>Cast Copper Alloy Fittings for Flared Copper Tube</i>
ASME	B16.23-1992	<i>Cast Copper Alloy Solder Joint Drainage Fittings - DWV</i>
ASME	B16.24-1998	<i>Bronze Pipe Flanges and Flanged Fittings</i>
MSS	SP106-1991	<i>Welded Fabricated Copper Solder Joint Pressure Fittings</i>
MSS	SP109-1997	<i>Non Ferrous Threaded and Solder Joint Unions For Use With Copper Water Tube</i>

EPC's wrot copper solder joint fittings also are manufactured to comply with the material performance and installation/joining dimensions of ANSI B16.22-1995.

The materials used to manufacture these fittings are also in compliance with the following specifications:

Tubular Wrought Copper:

ASTM B75 Alloy C12200, *Standard Specification for Seamless Copper Tube, or*

Products Made From Sheet:

ASTM B152 Alloy C11000, *Standard Specification for Copper Sheet, Strip, Plate and Rolled Bar.*

Cast Products:

ASTM B584 Alloy C84400, *Standard Specification for Copper Alloy Sand Castings for General Applications. Federal Specification WW-U-516 for Type 111, Class A and Class B Copper Alloy Unions.*

## The Advantages of Wrot Copper Fittings From EPC

Elkhart Products Corporation, Plumbing Products Division, manufactures a comprehensive line of Wrot Copper Solder-Joint fittings in sizes ranging from 1/8" to 8", which are shown on the following pages. Wrot Copper fittings have many advantages over their cast brass counterparts and Elkhart Products Corporation, recognizing the high rate of acceptability of the quality and well-designed fittings, is continually adding new items to this line.

These advantages show why EPC Wrot Copper Fittings are rapidly being accepted for copper installations in all parts of the country.

1. Reduced Installation Costs-EPC Wrot Copper Fittings heat up more rapidly than cast and thus effect a savings in time and fuel.
2. Smooth Inside Surface-Being fabricated from copper tube, EPC Wrot Fittings have no rough surfaces to collect waste or deter flow.
3. Full Flow Capacity-EPC Wrot Fittings have the same inside diameters as the rest of the installation.
4. Wrot Copper-The physical properties of copper tube from which EPC Wrot Fittings are made eliminate the danger of leakage from sand holes or poor castings.
5. Less Bulky than Cast-This facilitates handling, particularly on prefab installations, yet EPC Wrot Fittings have the same strength as tube. This can also be a money saver on transportation costs.
6. More Rugged-Due to fabrication processes, EPC Wrot Fittings are stronger and more rugged than tube with which they are used.
7. Priced Competitively-EPC Wrot Fittings cost no more than their cast counterparts.
8. Neat Appearance-In matching the color and appearance of the tube, EPC Wrot Fittings contribute toward a neater and more workman-like installation.
9. Accurate Pitch-EPC Wrot Fittings are made with accurately machined dies which ensure the proper pitch required for installations.
10. Boxed and Labeled-EPC Wrot Fittings are boxed in convenient quantities to facilitate handling and storage, and for protection against damage and dirt. Box contents are easily identified by bar coded, easy-to-read labels.

## Working Pressures and Solder

The table of maximum working pressures below must be understood to reflect what is generally considered as good engineering practice under reasonably constant and favorable conditions; i.e., pressures which are fairly steady, absence of particularly corrosive media, etc. Unusual conditions require increased safety factors and therefore, lower working pressures should be used.

## Rated Internal Working Pressures of Piping System Made of Copper Water Tube and Soldered Fittings

Solder Used in joints	Service Temp. °F	POUNDS PER SQUARE INCH Water (a)			
		Copper Water Tube-Nominal Sizes			
		½" to 1" Incl.	1¼" to 2" Incl.	2½" to 4" Incl.	5" to 8" Incl.
<b>* 50-50 Tin-Lead (b)</b>	100	200	175	150	135
	150	150	125	100	90
	200	100	90	75	70
	250	85	75	50	45
<b>95-5 Tin-Antimony (c) (d)</b>	100	500	400	300	270
	150	400	350	275	250
	200	300	250	200	180
	250	200	175	150	135
<b>Brazing Alloys Melting at or above 1000° F.</b>	<b>Temperature and pressure ratings consistent with the materials and procedures employed.</b>				

\*The data given for 50% tin-50% lead applies also for the 40% tin-60% lead alloy.

The values in this table are based on data in the National Bureau of Standards Publications, Building Materials and Structures Reports BMS 58 and BMS 83.

- (a) Including other noncorrosive liquids and gases
- (b) ASTM B32, Alloy Grade Sn 90
- (c) ASTM B32, Alloy Grade Sb 5
- (d) The Safe Drinking Water Act Amendment of 1986 prohibits the use in potable water. Systems of any solder having a lead content in excess of 2%.

NOTE: The table at left is from data published by the Copper and Brass Research Association.

## Estimated Quantity of 50-50 Solder Required to Make 100 Joints

Size in Inches	3/8	1/2	3/4	1	1 1/4	1 1/2	2	2 1/2	3	3 1/2	4	5	6	8
Quantity in Pounds	.5	.75	1.0	1.4	1.7	1.9	2.4	3.2	3.9	4.5	5.5	8	15	32

- The quantity of hard solder used is dependent in the skill of the operator, but for estimating purposes, 75% of the above figures may be used.
- Two ounces of Solder Flux will be required for each pound of solder.

## Wrot Copper and Bronze Solder-Joint Pressure Fittings

### Dimensions of Soldered-Joint Ends (in inches)

Standard Water Tube Size	Male End		Female End				Wall Thickness T	Inside Diameter of Fitting O
	Outside Diameter A	Length K	Inside Diameter F		Depth G			
			Min.	Max.		Min.	Max.	Min.
1/8	0.248	0.251	0.31	0.252	0.256	0.25	.019	0.18
1/4	0.373	0.376	0.38	0.377	0.381	0.31	.023	0.30
3/8	0.497	0.501	0.44	0.502	0.506	0.38	.026	0.39
1/2	0.622	0.626	0.56	0.627	0.631	0.50	.029	0.52
5/8	0.747	0.751	0.69	0.752	0.756	0.62	.031	0.63
3/4	0.872	0.876	0.81	0.877	0.881	0.75	.033	0.74
1	1.122	1.127	0.97	1.128	1.132	0.91	.040	0.98
1 1/4	1.372	1.377	1.03	1.378	1.382	0.97	.044	1.23
1 1/2	1.621	1.627	1.16	1.628	1.633	1.09	.051	1.47
2	2.121	2.127	1.41	2.128	2.133	1.34	.059	1.94
2 1/2	2.621	2.627	1.53	2.628	2.633	1.47	.067	2.42
3	3.121	3.127	1.72	3.128	3.133	1.66	.075	2.89
3 1/2	3.621	3.627	1.97	3.628	3.633	1.91	.086	3.37
4	4.121	4.127	2.22	4.128	4.133	2.16	.096	3.84
5	5.121	5.127	2.72	5.128	5.133	2.66	.111	4.70
6	6.121	6.127	3.22	6.128	6.133	3.09	.124	5.72
8	8.119	8.127	4.09	8.128	8.133	3.97	.173	7.55

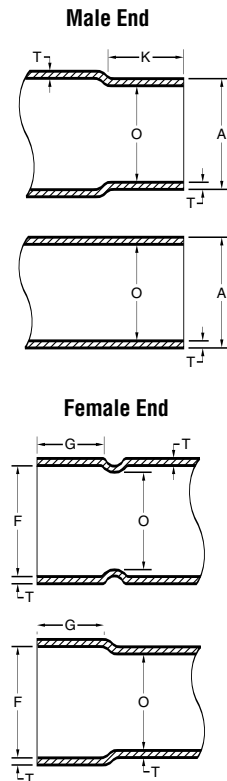

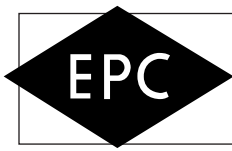

## Wrot Copper Solder-Joint Drainage Fittings

Dimensions of Soldered-Joint Ends (in inches) See Diagram Page 39

Size	Male End			Female End			Metal Thickness T	Inside Diameter of Fitting O
	Outside Diameter A		Length K	Inside Diameter F		Depth G		
	Min.	Max.	Min.	Min.	Max.	Min.		
1 1/4	1.372	1.377	0.56	1.378	1.382	0.50	0.040	1.29
1 1/2	1.621	1.627	0.62	1.628	1.633	0.56	0.042	1.53
2	2.121	2.127	0.69	2.128	2.133	0.62	0.042	2.01
3	3.121	3.127	0.81	3.128	3.133	0.75	1.045	2.98
4	4.121	4.127	1.06	4.128	4.133	1.00	0.058	3.93

Extracted from American National Standard Wrought Copper and Bronze Solder-Joint Drainage Fittings (ANSI B16.29) with permission of the publisher. The American Society of Mechanical Engineers, 3 Park Ave., New York, N.Y. 10016-5990

## Wrot Copper Fittings Large Diameter Welded Design

### Fitting Material:

Copper Alloy #122, Phosphorus  
Deoxidized-High Residual Phosphorus (DHP).  
Composition: 99% Copper; .015-.040% Phosphorus.

### Weld Material:

Silicon Bronze. Meets specification  
American Welding Society (AWS) A5.7-91R  
and American Metals Society. (AMS) 4616 B

### Weld Specifications:

Tensile Strength-Up to 58,000 PSI  
Yield Strength-Up to 25,000 PSI  
Elongation in 2"-53% to 55%  
Hardness-80 to 100 Brinell (500kg. Load)  
Temperature: Melt 1832°F, Flow 1931°F.

### Method of Joining:

Electric Weld.

### Dimensions & Specifications:

EPC Welded fittings are produced in accordance with specifications shown in Manufacturers Standardization Society (MSS) SP-109 for wrought copper, and copper alloy solder-joint pressure fittings.

### Testing:

Each fitting is individually tested with air under water. The burst pressure of EPC welded fittings exceeds the recommended working pressure of comparable diameter, annealed, straight, seamless ASTM B88-96-A type L copper water tube by a safety factor

## Copper Water Tube-Standard Dimensions and Weights

Nominal Tube Size Inches	Outside Dia., In.	Inside Diameter, Inches				Wall Thickness, Inches				†Pounds per Linear Foot			
	Types K-L-M- DWV	Type K	Type L	Type M	Type DWV	Type K	Type L	Type M	Type DWV	Type K	Type L	Type M	Type DWV
1/4	.375	.305	.315	-	-	.035	.030	.025	-	.145	.126	.106	-
3/8	.500	.402	.430	-	-	.049	.035	.025	-	.269	.198	.145	-
1/2	.625	.527	.545	-	-	.049	.040	.028	-	.344	.285	.204	-
5/8	.750	.652	.666	-	-	.049	.042	.030	-	.418	.362	.263	-
3/4	.875	.745	.785	-	-	.065	.045	.032	-	.641	.455	.328	-
1	1.125	.995	1.025	-	-	.065	.050	.035	-	.839	.655	.465	-
1 1/4	1.375	1.245	1.265	1.291	1.295	.065	.055	.042	.040	1.04	.884	.682	.650
1 1/2	1.625	1.481	1.505	1.527	1.541	.072	.060	.049	.042	1.36	1.14	.940	.809
2	2.125	1.959	1.985	2.009	2.041	.083	.070	.058	.042	2.06	1.75	1.46	1.07
2 1/2	2.625	2.435	2.465	2.495	-	.095	.080	.065	-	2.93	2.48	2.03	-
3	3.125	2.907	2.945	2.981	3.035	.109	.090	.072	.045	4.00	3.33	2.68	1.69
3 1/2	3.625	3.385	3.425	3.459	-	.120	.100	.083	-	5.12	4.29	3.58	-
4	4.125	3.857	3.905	3.935	4.009	.134	.110	.095	.058	6.51	5.38	4.66	2.87
5	5.125	4.805	4.875	4.907	4.981	.160	.125	.109	.072	9.67	7.61	6.66	4.43
6	6.125	5.741	5.845	5.881	5.959	.192	.140	.122	.083	13.9	10.2	8.92	6.10
8	8.125	7.583	7.725	7.785	-	.271	.200	.170	-	25.9	19.3	16.5	-

## Copper Water Tube-Calculated Bursting Pressure\*

## Sizes of Copper Tube

Nominal Tube Size, Inches	Outside Diameter, In.	Inside Diameter Inches		Wall Thickness Inches		Bursting Pressure Lb. per Sq. In.				
		Types K-L	Type K	Type L	Type K	Type L	Type K		Type L	
							Hard (Drawn)	Soft (Annealed)	Hard (Drawn)	Soft (Annealed)
1/4	.375	.305	.315	.035	.030	6,700	5,600	5,800	4,800	
3/8	.500	.402	.430	.049	.035	7,100	5,900	5,000	4,200	
1/2	.625	.527	.545	.049	.040	5,600	4,700	4,600	3,800	
5/8	.750	.652	.666	.049	.042	4,700	3,900	4,000	3,400	
3/4	.875	.745	.785	.065	.045	5,300	4,500	3,700	3,100	
1	1.125	.995	1.025	.065	.050	4,200	3,500	3,200	2,700	
1 1/4	1.375	1.245	1.265	.065	.055	3,400	2,800	2,900	2,400	
1 1/2	1.625	1.481	1.505	.072	.060	3,200	2,700	2,700	2,200	
2	2.125	1.959	1.985	.083	.070	2,800	2,300	2,400	2,000	
2 1/2	2.625	2.435	2.465	.095	.080	2,600	2,200	2,200	1,800	
3	3.125	2.907	2.945	.109	.090	2,500	2,100	2,100	1,700	
3 1/2	3.625	3.385	3.425	.120	.100	2,400	2,000	2,000	1,700	
4	4.125	3.857	3.905	.134	.110	2,300	1,900	1,900	1,600	
5	5.125	4.805	4.875	.160	.125	2,200	1,900	1,800	1,500	
6	6.125	5.741	5.845	.192	.140	2,300	1,900	1,600	1,400	
8	8.125	7.583	7.725	.271	.200	2,400	2,000	1,800	1,500	

OD Size	Nominal Size
1/8	-
3/16	-
1/4	1/8
5/16	-
3/8	1/4
1/2	3/8
5/8	1/2
3/4	5/8
7/8	3/4
1	7/8
1 1/8	1
1 1/4	1 1/8
1 3/8	1 1/4
1 5/8	1 1/2
2 1/8	2
2 5/8	2 1/2
3 1/8	3
3 5/8	3 1/2
4 1/8	4
5 1/8	5
6 1/8	6
8 1/8	8

\*Bursting Pressures are calculated from the following formula for thin, hollow cylinders under tension.  
 where  $P = \frac{2tS}{D}$   
 P = Bursting Pressure, Lb. per Sq. In.  
 t = Wall Thickness, Inches  
 D = Outside Tube Diameter, Inches  
 S = Tensile Strength (36,000 Lb. per Sq. In. for hard tubes and 30,000 for soft tubes)

## Soldering and Brazing Copper Tube

Soldering and Brazing with capillary solder joint fittings is the most common system for joining copper tube. The American Welding Society defines soldering as a joining process which takes place below 840° and brazing as a similar process which occurs above 840°.

The basic theory and technique of soldering and brazing are the same for all diameters...the variables are: the amount of time, heat and filler metal required to complete a designated joint. A good joint is the product of a well trained craftsman who knows and respects the materials and methods he uses.

### Basic Steps in Joining Process

**Measuring** - Measuring the length of the tube must be accurate. If the tube is too short it will not reach all the way into the socket of the fitting and a proper joint cannot be made.

**Cutting** - Cutting tube can be accomplished in a number of different ways to produce a satisfactory, square-end cut. The tube can be cut with a disc type tube cutter, a hacksaw, abrasive wheels, or stationary and portable bandsaws. Care must be taken that the tube is not deformed while being cut. Regardless of the cutting method used, the cut must be square with the run of the tube so that it will seat properly in the fitting socket.

**Reaming** - Most methods of cutting leave a small burr on the end of the tube. Unless these rough edges are removed, erosion-corrosion may occur due to local turbulence and increased velocities in the tube. Tools used to ream tube ends include the reaming blade on the tube cutter half-round or round files, a pocket knife, or a suitable deburring tool. With annealed tube, care must be taken not to get the tube end out-of-round by applying too much pressure. Both the inside and the outside of the tube may require removal of the burr. A properly reamed piece of tube will provide a smooth surface for better flow.

**Cleaning** - Cleaning is quickly and easily done. The removal of oxides and surface soil is crucial if filler metal is to flow properly. Oxides, surface soil and oil can interfere with the strength of the joint and this may result in the joint's failure. Mechanical cleaning is a simple operation. The end of the tube should be cleaned using sand cloth or nylon abrasive pads for a distance only slightly more than the depth of the fitting socket. The socket of the fitting should also be cleaned using sand cloth, abrasive pads, or properly sized fitting brushes. The same precautions, as when reaming the tube, should be observed.

Copper is a soft metal; if too much material is removed, a loose fit will result and interfere with satisfactory capillary action in making the joint. The capillary space between tube and fitting is approximately .004-in. Solder or brazing filler metal can fill this gap by capillary action. This spacing is critical for the filler metal to flow into the gap and form a strong joint. Chemical cleaning may be utilized, providing the tube and fittings are thoroughly rinsed, according to the manufacturer's recommendations furnished with the cleaner. This will help neutralize any acidic conditions that may exist. The surfaces, once cleaned, should not be touched with bare hands or oily gloves. Skin oils, lubricating oils and grease impair solder flow and wetting.

### Temperature Ranges

Up to this point, the joining process is the same for both soldering and brazing. The choice for soldering or brazing will depend upon operating conditions. Solder joints are generally used where the system temperatures do not exceed 250° F and brazed joints can be used where greater strengths are required, or where system temperatures are as high as 350° F. In actual practice, most soldering is done at temperatures about 350° F to 550° F, while brazing is done at temperatures ranging from 1100° F to 1550° F.

Because of the differences in the soldering and brazing process, each will be discussed separately.

## Soldering

**Applying Flux** - A non-aggressive soldering flux is recommended. Stir the flux before use. A good flux will dissolve and remove traces of residual oxides from the surfaces to be joined, protect the surfaces from re-oxidation during heating and promote the wetting of the surfaces by the solder. A thin, even coating of flux should be applied with a brush to both tube and fitting. Avoid the use of fingers to apply flux. Chemicals in the flux can be harmful if carried to the eyes or open cuts.

**Types of Solder** - There are a variety of solders available that will produce sound, leak-tight joints. Solders that are used for piping applications contain tin and varying amounts of either antimony, copper, lead or silver. Choice of solder will depend upon application and local codes. For potable water systems, solders which do not contain lead are the best choice.

**Assembly** - After both surfaces are properly fluxed, they should be assembled by placing the fitting on the tube, making sure the tube seats against the base of the fitting socket. A slight twisting motion is suggested to ensure even coverage by the flux. Remove the excess flux with a rag. Because of the heat that is required during soldering and brazing, only cotton rags should be used. Complete all prepared joints within a single work day. Care must be taken to assure that the tube and fittings are properly supported with a reasonable, uniform capillary space around the entire circumference of the joint. Uniformity of capillary space will ensure good filler metal penetration if the guidelines of successful joint making are followed. Excessive joint clearance can cause the filler metal to crack under stress or vibration.

**Heating** - Because of the open flame and high temperatures required for soldering and the flammability of the gases used, safety precautions must be observed. The heat is generally applied by use of an air/fuel torch. These torches can cause acetylene or a variety of LP gases. Electric resistance pliers can also be used.

Heating should begin with the flame perpendicular to the tube. This preheat will conduct the initial heat into the socket for even distribution of heat inside and out. Preheating depends upon the size of the joint - experience will indicate the proper amount of time. The flame should not be moved onto the fitting. Move the flame from the fitting socket onto the tube a distance equal to the fitting socket. Touch the solder to the joint. If the solder does not melt, remove it and continue the heating process. Be careful not to overheat or direct the flame into the fitting cup. This action can cause the flux to burn and destroy its effectiveness. When the melting temperature has been reached, heat may be applied to the base of the cup to aid capillary action in drawing the solder into the cup.

**Applying Solder** - When the tube is in a horizontal position, start applying the solder slightly off-center of the bottom of the joint. Proceed across the bottom of the fitting and up to the top-center position. Return to the point of beginning, overlap the starting point and then proceed up the incompleting side to the top. Again, overlapping the solder. Molten solder will be drawn into the joint by capillary action regardless if the solder is being fed upward, downward or horizontally.

**Cooling & Cleaning** - After the joint has been completed, natural cooling is best. Shock cooling may cause unnecessary stresses on the joint and may result in eventual failure. Once the fitting is cool, clean off any remaining flux with a wet rag.

## Brazing

**Applying Flux** - The fluxes used for brazing copper joints are different in composition from soldering fluxes. They cannot, and should not, be used interchangeably.

Brazing fluxes are water based. Similar to soldering fluxes, brazing fluxes dissolve and remove residual oxides from the metal surfaces, they protect the metal

surfaces from re-oxidation during heating and they promote the wetting of the surfaces to be joined by the brazing filler metal. Fluxes also provide the craftsman with an indication of temperature. Application of the flux is the same as when soldering. If the outside of the fitting and the heat affected area of the tube are covered with flux, it will prevent oxidation and greatly improve the appearance of the joint.

**Brazing Filler Metals** - There are two general types of brazing filler metal used for joining copper tube: BCuP (Brazing - Copper - Phosphorus) and BA9 (Brazing - Silver). These brazing filler metals are classified according to their components.

BCuP filler metals are preferred for joining copper tube and fittings. The phosphorus in these filler metals acts as a fluxing agent and the lower percentage of silver makes them relatively low cost filler metals. When using copper tube, wrought copper fittings and BCuP brazing filler metal, fluxing is an option due to the self-fluxing action of the phosphorus present in all components of the brazed joint.

The choice of brazing filler metals depends upon four main factors:

- dimensional tolerance of the joint
- type and material of fitting (cast or wrought)
- desired appearance
- cost

**Heating** - Oxy/fuel torches are generally used when brazing because of the higher temperatures required. Due to recent innovations in air/fuel torch tip design, they can now be used on a wider variety of size for soldering and brazing.

When working with temperatures this high, safety precautions must be followed and care taken to protect both the operator and the materials being used.

The heating operation is the same as for soldering. First preheat the tube and then the tube and fitting. When the brazing filler metal starts to melt, apply the heat at the base of the fitting socket to help draw the brazing filler metal in by capillary action.

**Applying Brazing Filler Metal** - Remember to allow the heat of the joint to melt the filler metal. Do not melt the filler metal with the torch. The melted filler metal will be drawn into the joint by capillary action. It is very important that the flame be in continuous motion and should not be allowed to remain on any one point long enough to burn through the tube or fitting. When the joint is complete, a continuous filler should be visible completely around the joint. If the filler metal fails to flow, or has the tendency to ball-up, it indicates oxidation on the metal surfaces or insufficient heat on the parts to be joined. If the filler metal refuses to enter the joint and tends to flow over the outside of either part of the joint, it indicates that this part is overheated or that the other part is underheated.

**Cooling and Cleaning** - When the joint is complete, allow it to cool naturally. Flux residues can be removed by washing with hot water and brushing with a stainless steel wire brush.

## Summary

If the parts to be joined are properly prepared, properly heated and the correct filler metal is used, the finished joint should be sound. Soldered or brazed copper piping systems, when installed properly, will provide years of safe and reliable service. Proper training of the correct installation techniques, such as those just covered, will give the craftsman the ability to achieve consistently reliable soldered and brazed joints in all diameters.

*Prepared with technical assistance from the Copper Development Association.*

## Rated Internal Working Pressures for Copper Tube Types K, L, M and DWV

Size, Inches	Rated Internal Working Pressures, psi.							
	Type K		Type L		Type M		Type DWV	
	Annealed	Drawn	Annealed	Drawn	Annealed	Drawn	Annealed	Drawn
(Service Temperature up to 150°F (S = 5,100 psi, annealed 9,000 psi, drawn))								
1/4	913	2029	775	1722	-	-	-	-
3/8	979	2135	662	1471	485	1077	-	-
1/2	769	1683	614	1362	420	932	-	-
5/8	633	1389	536	1192	-	-	-	-
3/4	735	1609	495	1099	346	769	-	-
1	563	1236	420	933	286	636	-	-
1 1/4	456	1003	373	823	287	638	280	621
1 1/2	424	933	347	771	281	625	249	552
2	372	820	309	686	254	563	185	410
2 1/2	341	751	286	633	233	517	-	-
3	330	579	269	476	215	380	135	239
3 1/2	313	549	258	456	214	378	-	-
4	308	540	249	440	313	377	128	225
5	295	517	229	404	198	349	128	227
6	296	520	213	376	185	328	126	223
8	315	554	230	406	195	344	124	219
10	315	554	230	407	196	345	-	-
12	316	555	213	375	196	345	-	-
(Service Temperature up to 200°F (S = 4,800 psi, annealed 9,000 psi, drawn))								
1/4	860	2029	730	1722	-	-	-	-
3/8	921	2135	623	1471	456	1077	-	-
1/2	724	1683	578	1362	395	932	-	-
5/8	596	1389	505	1192	-	-	-	-
3/4	691	1609	466	1099	326	769	-	-
1	530	1236	395	933	270	636	-	-
1 1/4	429	1003	351	828	270	638	264	621
1 1/2	399	933	326	771	265	625	235	552
2	350	820	291	686	239	563	174	410
2 1/2	321	751	269	633	219	517	-	-
3	310	579	254	476	202	380	127	239
3 1/2	294	549	243	456	202	378	-	-
4	290	540	234	440	201	377	120	225
5	278	517	215	404	186	349	121	227
6	278	520	201	376	174	328	118	223
8	297	554	216	406	183	344	117	219
10	297	554	217	407	184	345	-	-
12	298	555	200	375	184	345	-	-
(Service Temperature up to 300°F (S = 4,700 psi, annealed 8,700 psi, drawn))								
1/4	842	1974	714	1676	-	-	-	-
3/8	902	2077	610	1431	446	1048	-	-
1/2	709	1638	565	1325	387	907	-	-
5/8	583	1351	494	1160	-	-	-	-
3/4	662	1566	456	1069	319	748	-	-
1	520	1203	387	908	264	619	-	-
1 1/4	420	976	344	806	265	621	258	604
1 1/2	391	908	319	750	359	608	230	537
2	343	798	285	667	234	548	170	399
2 1/2	314	731	263	616	215	503	-	-
3	304	560	248	449	198	367	124	231
3 1/2	288	531	238	441	197	366	-	-
4	283	522	229	425	197	365	117	218
5	272	500	211	391	182	337	118	220
6	272	502	197	364	171	317	116	216
8	290	535	211	393	179	333	114	209
10	290	535	212	394	180	334	-	-
12	291	536	196	363	180	334	-	-

Continued on next page

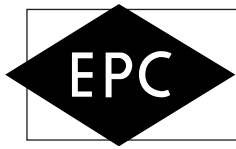

# Engineering Data

Continued from previous page

Size, Inches	Rated Internal Working Pressures, psi							
	Type K		Type L		Type M		Type DWV	
	Annealed	Drawn	Annealed	Drawn	Annealed	Drawn	Annealed	Drawn
(Service Temperature up to 400°F (S = 4,700 psi, annealed 8,700 psi, drawn))								
1/4	537	771	456	654	-	-	-	-
3/8	576	811	390	559	285	409	-	-
1/2	453	640	361	518	247	354	-	-
5/8	373	528	316	453	-	-	-	-
3/4	432	611	291	418	204	292	-	-
1	331	470	247	355	169	242	-	-
1 1/4	268	381	220	315	169	242	165	236
1 1/2	250	355	204	293	166	238	147	210
2	219	312	182	261	150	214	109	156
2 1/2	201	285	168	241	137	196	-	-
3	194	527	159	520	127	346	80	218
3 1/2	184	500	152	415	126	344	-	-
4	181	492	147	401	126	343	75	205
5	174	471	135	368	117	318	76	207
6	174	474	126	343	109	299	74	203
8	186	505	135	370	115	313	73	200
10	186	505	136	371	115	314	-	-
12	186	506	125	342	115	314	-	-

## Fractional Inch/Decimal Inch/Millimeters Conversion Chart

Fractional Inch	Decimal Inch	Millimeters	Fractional Inch	Decimal Inch	Millimeters	Fractional Inch	Decimal Inch	Millimeters
1/64	.0156	.396	23/64	.3593	9.128	45/64	.7031	17.859
1/32	.0312	.793	3/8	.375	9.525	23/32	.7187	18.256
3/64	.0468	1.190	25/64	.3906	9.921	47/64	.7343	18.653
1/16	.0625	1.587	13/32	.4062	10.318	3/4	.750	19.050
5/64	.0781	1.984	27/64	.4218	10.715	49/64	.7656	19.446
3/32	.0937	2.381	7/16	.4375	11.112	25/32	.7812	19.843
7/64	.1093	2.778	29/64	.4531	11.509	51/64	.7968	20.240
1/8	.125	3.175	15/32	.4687	11.906	13/16	.8125	20.637
9/64	.1406	3.571	31/64	.4843	12.303	53/64	.8281	20.034
5/32	.1562	3.968	1/2	.500	12.700	27/32	.8437	21.431
11/64	.1718	4.365	33/64	.5156	13.096	55/64	.8593	21.828
3/16	.1875	4.762	17/32	.5312	13.493	7/8	.875	22.225
13/64	.2031	5.159	35/64	.5468	13.890	57/64	.8906	22.621
7/32	.2187	5.556	9/16	.5625	14.287	29/32	.9062	23.018
15/64	.2343	5.953	37/64	.5781	14.684	59/64	.9218	23.415
1/4	.250	6.350	19/32	.5937	15.081	15/16	.9375	23.812
17/64	.2656	6.746	39/64	.6093	15.478	61/64	.9531	24.209
9/32	.2812	7.143	5/8	.625	15.875	31/32	.9687	24.606
19/64	.2968	7.540	41/64	.6406	16.271	63/64	.9843	25.003
5/16	.3125	7.937	21/32	.6562	16.668	1	1.000	25.400
21/64	.3281	8.334	43/64	.6718	17.065			
11/32	.3437	8.731	11/16	.6875	17.462			



Mueller Streamline Co.  
8285 Tournament Drive, Suite 150  
Memphis, TN 38125  
P 901.753.3200

## STANDARD COPPER TUBE

Mueller Copper Tube products are manufactured in the USA. All tubing produced in Fulton, MS, and Wynne, AR, is seamless and of UNS C12200 grade of copper and is manufactured to meet the chemical, mechanical, cleanness, and eddy current testing requirements of the applicable ASTM specifications set forth below.

Although Mueller Copper Tube strives to meet all requirements specified in ASTM, Standard Tube may not fully meet ASTM dimensional requirements. Standard Tube will be provided unless Certified Tube is clearly defined on the Purchase Order. When specified at order placement, Mueller Copper Tube can supply Certified Tube to meet all requirements of the current applicable ASTM specification, at an additional cost.

- Streamline Copper Water Tube (Types K,L,M) is produced in accordance with, ASTM B88 and ANSI/NSF 61 \*\*
- Streamline Copper Refrigeration Service Coils are produced in accordance with ASTM B280
- Streamline Nitrogenized ACR Hard Drawn Copper Tube is produced in accordance with ASTM B280
- Streamline Copper Drainage Tube (DWV) is produced in accordance with ASTM B306
- Oxygen & Medical Service Tube - To ASTM B819 (Types K & L) Hard Drawn Straight Lengths Only in accordance to CGA Cleanness Specification; CGA G4.1 (Compressed Gas Association); & NFPA 99 (Health Care Facilities).

\*\* NSF 61 Restriction Statement Copper Tube (Alloy C12200) is certified by NSF to ANSI/NSF Standard 61 for public water supplies meeting or in the process of meeting the U.S. EPA Lead and Copper Rule (56FR 26460, June 7, 1991). Water supplies with pH less than 6.5 may require corrosion control to limit copper solubility in drinking water."

Last revision: March 11, 2011

# Submittal Package

**viega**



## ProPress® System

- Potable Water
- Hydronic Heating
- Chilled Water
- Compressed Air
- Nitrogen N<sub>2</sub>
- Argon
- Low Pressure Steam
- Fire Protection
- Vacuum
- Corgon
- Oxygen O<sub>2</sub> (non medical)
- \_\_\_\_\_

# Submittal Package

**viega**

## System Data Sheet

### System Description

Viega ProPress and Viega ProPress XL (copper) are safe, reliable and economical copper pipe installation systems that use modern cold press connection technology for a wide assortment of more than 600 fittings in dimensions ranging from ½" to 4". ProPress utilizes an EPDM sealing element to provide permanent leak-proof connections.

Tubing: K, L and M hard copper tubing from ½" to 4" and soft copper tubing in ½" to 1¼" diameters.

### Applications

All tubing must comply with the ASTM B88 standard. Viega ProPress fittings are approved for installations in both above- and below-ground applications. Per code, local inspector approval must be obtained prior to installation below ground.

### Operating Parameters

Operating Pressure: 200 psi Max.

Test Pressure: 600 psi Max.

Low-Pressure Steam: 15 psi Max.

Vacuum: 29.2" Mercury Max. @ 68°F

Operating Temperature: 0°F to 250°F

### Approved Applications

- Potable Water
- Hydronic Heating (w/ Glycol)
- Chilled Water
- Compressed Air (200 psi max.)
- Non-medical Gases (140 psi maximum)
- Fire Sprinkler (175 psi maximum)
- Low Pressure Steam (15 psi maximum)
- Vacuum (29.2" Mercury maximum @ 68°F)

### System Benefits

- Fast and Easy to Use
- Flameless
- Permanent Connections
- Large Selection of Fittings from ½" to 4"
- Consistent Professional Appearance
- Less Equipment Required
- Environmentally Friendly Connection System
- Versatility of Fittings and Tools for Variety of Applications

### Fittings

There are more than 600 Viega ProPress fittings including: Elbows, Couplings, Reducers, Tees, Reducing Tees, Threaded Adapters, Unions, Caps and Flanges. All threaded ½" - 2" fittings are bronze. Viega ProPress and Viega ProPress XL (copper) fittings conform to NSF 61 Annex G.

### Smart Connect Feature

The Smart Connect feature is a special indentation in the inside surface of the fitting near the sealing element. This indentation assures leakage of liquids and/or gases from inside the system past the sealing element of an unpressed connection. The indentation is removed during the pressing process, creating a

leak-free, permanent connection. This feature provides quick and easy identification of connections that have not been pressed prior to putting the system into operation.

### Tools

RIDGID offers pressing tools for connecting Viega ProPress fittings.

- RIDGID RP 200-B (½" to 1¼")
- RIDGID RP 210-B (½" to 1¼")
- RIDGID RP 320-B
- RIDGID RP 330-B
- RIDGID RP 340-B
- RIDGID CT-400

### History

Viega ProPress has been used in Europe since the late 1980s and in the U.S. since the late 1990s for a variety of applications.

### Warranty

Viega ProPress products carry a 50-year warranty against defects in material and workmanship. ProPress valves carry a 2-year warranty against defects in material and workmanship.

### Listings and Certificates

- NSF 61G
- IAPMO PS117
- UL 213
- FM Class 1920
- ICC-ES PMG 1037
- CSA MSE-13
- ABS
- CRN OA4541.5

### International Listings and Certificates

- Deutsch Verein des Gas-und Wasserfachese.V. (DVGW)
- Lloyd's Register (LLOYD'S)
- Det Norske Veritas (DNV)
- Registro Italiano Navale (RINA)
- Bureau Veritas (BV)
- KIWA

### Compliant with:

- ICC International Plumbing Code
- IAPMO Uniform Plumbing Code
- PHCC National Standard Plumbing Code
- NFPA 13, 13D and 13R
- ASME B16.51
- U.S. Coast Guard

Contact your local Viega representative for details on local approvals

### For more information on RIDGID products, contact:

Ridge Tool Company  
400 Clark Street, Elyria, Ohio 44036  
Demos, Literature: 800-769-7743  
Technical inquiries: 800-519-3456  
Availability: 888-743-4333  
Web: www.ridgid.com

# Submittal Package

**viega**

## Viega ProPress®

For Types K, L and M Hard Copper Tubing in 1/2" to 2" and Soft Copper Tubing in 1/2" to 1 1/4"

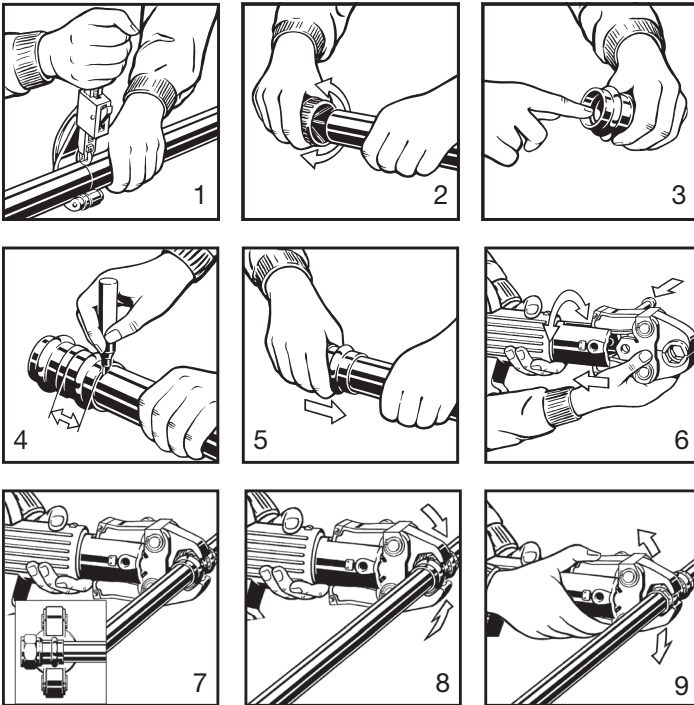

**⚠ WARNING** Read and understand all instructions for installing Viega ProPress fittings. Failure to follow all instructions may result in extensive property damage, serious injury or death.

1. Cut copper tubing at right angles using displacement-type cutter or fine-toothed steel saw.
2. Remove burr from inside and outside of tubing to prevent cutting sealing element.
3. Check seal for correct fit. Do not use oils or lubricants. Use only Viega ProPress Shiny Black EPDM or Dull Black FKM sealing elements.  
**Note:** For applications requiring Viega ProPress with FKM sealing elements, remove the factory-installed EPDM sealing element and replace with FKM sealing element.
4. Mark proper insertion depth as indicated by the Viega ProPress Insertion Depth Chart. Improper insertion depth may result in improper seal.
5. While turning slightly, slide press fitting onto tubing to the marked depth.  
**Note:** End of tubing must contact stop.
6. Insert appropriate Viega jaw into the pressing tool and push in, holding pin until it locks in place.
7. Open the jaw and place at right angles on the fitting. Visually check insertion depth using mark on tubing.
8. Start pressing process and hold the trigger until the jaw has engaged the fitting.
9. After pressing, the jaw can be opened again.

**Viega ProPress Insertion Depth Chart**

Tube Size	1/2"	3/4"	1"	1 1/4"	1 1/2"	2"
Insertion Depth	3/4"	7/8"	7/8"	1"	17/16"	1 9/16"



### Leak Testing with Smart Connect®:

Unpressed connections are located by pressurizing the system with air or water. When testing with water the proper pressure range is 15 psi to 85 psi maximum. Leak testing with air can be dangerous at high pressures. When testing with compressed air the proper pressure range is 1/2 psi to 45 psi maximum. Following a successful leak test, the system may be pressure tested up to 200 psi with air, or up to 600 psi with water, if required by local code requirements or project specifications.

# Submittal Package



## Viega ProPress® XL (Copper)

For Types K, L and M Hard Copper Tubing in 2½" to 4"

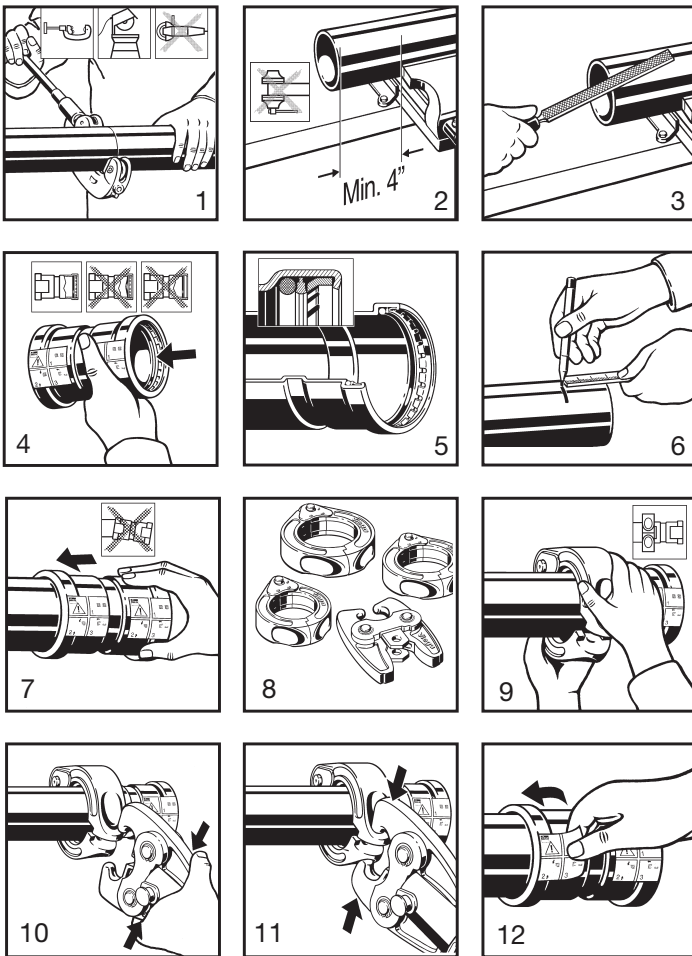

Tube Size	2½"	3"	4"
Insertion Depth	1⅝"	1⅞"	2⅝"

**⚠ WARNING** Read, understand and follow all instructions for installing ProPress XL (copper) fittings. Failure to follow all instructions may result in extensive property damage, serious injury or death.

1. Cut copper tubing at right angles using displacement-type cutter or fine-toothed steel saw.
2. Keep end of tubing a minimum of 4" away from the contact area of the vise to prevent possible damage to the tubing in the press area.
3. Remove burr from inside and outside of tubing to prevent cutting sealing element.
4. Check seal and grip ring for correct fit. Do not use oils or lubricants. Use only ProPress Shiny Black EPDM sealing elements.
5. Illustration demonstrates proper fit of grip ring, separation ring and sealing element.
6. Mark proper insertion depth as indicated by the ProPress XL (copper) Insertion Depth Chart. Improper insertion depth may result in an improper seal.
7. While turning slightly, slide press fitting onto tubing to the marked depth. End of tubing must contact stop.
8. ProPress XL (copper) fitting connections must be performed with ProPress XL-C Rings and V2 ACTUATOR. Use of ProPress XL Rings and/or Actuator (for Bronze fittings) will result in an improper connection. See Ridgid Operator's Manual for proper tool instructions.
9. Open XL-C Ring and place at right angles on the fitting. XL-C Ring must be engaged on the fitting bead. Check insertion depth.
10. With V2 ACTUATOR inserted into the tool, open the V2 ACTUATOR as shown and connect V2 ACTUATOR to the XL-C Ring.
11. Place V2 ACTUATOR onto XL-C Ring and start pressing process. Hold the trigger until the Actuator has engaged the XL-C Ring. Keep extremities and foreign objects away from XL-C Ring and V2 ACTUATOR during pressing operation to prevent injury or incomplete press.
12. Release V2 ACTUATOR from XL-C Ring and then remove the XL-C Ring from the fitting on completion of press. Remove tag from fitting, indicating press has been performed.

**Leak Testing with Smart Connect®:** Unpressed connections are located by pressurizing the system with air or water. When testing with water the proper pressure range is 15 psi to 85 psi maximum. Leak testing with air can be dangerous at high pressures. When testing with compressed air the proper pressure range is ½ psi to 45 psi maximum. Following a successful leak test, the system may be pressure tested up to 200 psi with air, or up to 600 psi with water, if required by local code requirements or project specifications.

# Submittal Package

**viega**

## ProPress® Dimensional Documentation

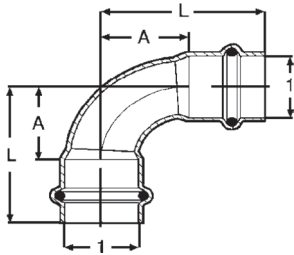

Viega ProPress 90° Elbow Copper P x P - Model 2916

Part No.	Size	A (in)	L (in)
	<b>1</b>		
77317	½"	0.75	1.50
77322	¾"	1.04	1.94
77327	1"	1.32	2.23
77332	1¼"	1.65	2.68
77337	1½"	1.98	3.40
77342	2"	2.54	4.13

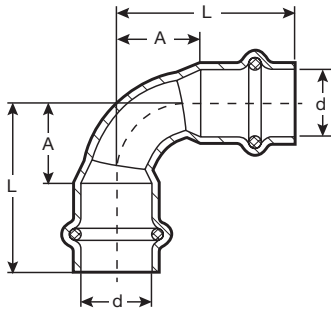

Viega ProPress 90° Elbow Copper P x P - Model 2916 Short

Part No.	Size	A (in)	L (in)
	<b>1</b>		
77317	½"	0.75	1.50
77022	¾"	0.76	1.67
77027	1"	1.28	2.19
77032	1¼"	1.28	2.31
77037	1½"	1.29	2.72
77042	2"	2.16	3.74

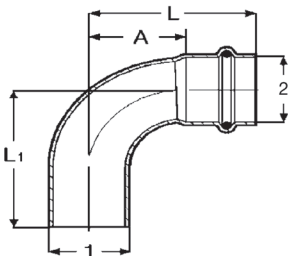

Viega ProPress 90° Street Elbow Copper P x FTG - Model 2916.1

Part No.	Size	A (in)	L (in)	L1 (in)
	<b>1</b> <b>2</b>			
77347	½" x ½"	0.75	1.50	1.54
77352	¾" x ¾"	1.04	1.94	1.98
77357	1" x 1"	1.32	2.23	2.27
77362	1¼" x 1¼"	1.65	2.68	2.76
77367	1½" x 1½"	1.98	3.40	3.48
77372	2" x 2"	2.54	4.13	4.20

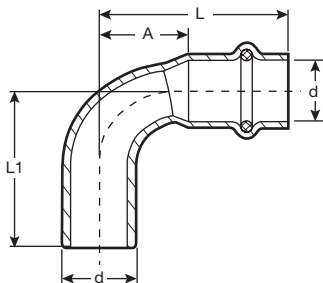

Viega ProPress 90° Elbow Copper P x FTG - Model 2916.1 Short

Part No.	Size	A (in)	L (in)	L1 (in)
	<b>1</b>			
77347	½"	0.75	1.50	1.54
77052	¾"	0.76	1.67	1.83
77057	1"	1.28	2.19	2.27
77062	1¼"	1.28	2.31	2.48
77067	1½"	1.29	2.72	2.80
77072	2"	2.16	3.74	3.78

# Submittal Package

**viega**

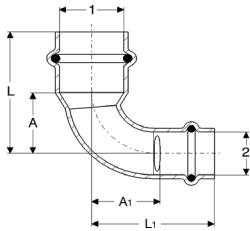

**Viega ProPress 90° Reducing Elbow Copper P x P - Model 2916.3**

Part No.	Size		A (in)	A1 (in)	L (in)	L1 (in)
	1	2				
77325	3/4"	1/2"	0.91	0.94	1.81	1.69
77330	1"	3/4"	1.20	1.30	2.11	2.21

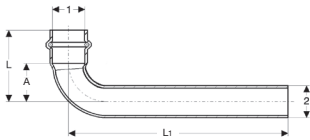

**Viega ProPress 90° Extended Street Elbow Copper P x FTG - Model 2947**

Part No.	Size		A (in)	L (in)	L1 (in)
	1	2			
77353	3/4"	3/4"	1.02	1.93	5.98

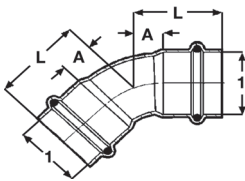

**Viega ProPress 45° Elbow Copper P x P - Model 2926**

Part No.	Size		A (in)	L (in)
	1	2		
77607	1/2"		0.30	1.04
77612	3/4"		0.43	1.34
77617	1"		0.55	1.46
77622	1 1/4"		0.68	1.71
77627	1 1/2"		0.81	2.24
77632	2"		0.81	2.63

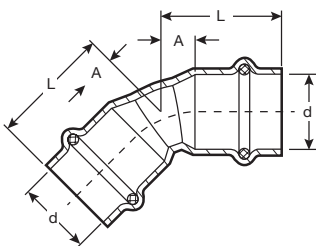

**Viega ProPress 45° Elbow Copper P x P - Model 2926 Short**

Part No.	Size		A (in)	L (in)
	1	2		
77607	1/2"		0.30	1.04
77023	3/4"		0.36	1.26
77028	1"		0.47	1.38
77033	1 1/4"		0.58	1.61
77038	1 1/2"		0.65	2.08
77043	2"		0.86	2.44

# Submittal Package

**viega**

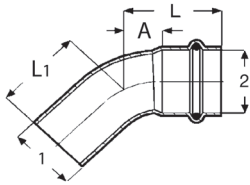

**Viega ProPress 45° Street Elbow Copper P x FTG - Model 2926.1**

Part No.	Size	A (in)	L (in)	L1 (in)
	1 2			
77637	1/2" x 1/2"	0.31	1.06	1.10
77642	3/4" x 3/4"	0.43	1.34	1.37
77647	1" x 1"	0.55	1.46	1.49
77652	1 1/4" x 1 1/4"	0.68	1.71	1.79
77657	1 1/2" x 1 1/2"	0.81	2.24	2.32
77662	2" x 2"	1.05	2.63	2.71

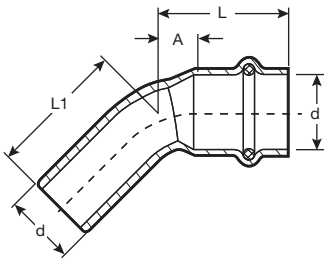

**Viega ProPress 45° Elbow Copper P x FTG - Model 2926.1 Short**

Part No.	Size	A (in)	L (in)	L1 (in)
	1			
77637	1/2"	0.31	1.06	1.10
77053	3/4"	0.36	1.26	1.30
77058	1"	0.47	1.38	1.49
77063	1 1/4"	0.58	1.61	1.67
77068	1 1/2"	0.65	2.08	2.04
77073	2"	0.86	2.44	2.54

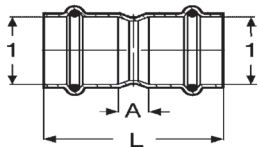

**Viega ProPress Coupling with Stop Copper P x P - Model 2915**

Part No.	Size	A (in)	L (in)
	1		
78047	1/2"	0.12	1.61
78052	3/4"	0.20	2.01
78057	1"	0.16	1.97
78062	1 1/4"	0.14	2.20
78067	1 1/2"	0.14	2.99
78072	2"	0.14	3.31

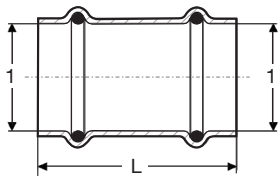

**Viega ProPress Coupling No Stop Copper P x P - Model 2915.3**

Part No.	Size	L (in)
	1	
78172	1/2"	1.61
78177	3/4"	2.01
78182	1"	1.97
78187	1 1/4"	2.20
78192	1 1/2"	2.99
78197	2"	3.31

# Submittal Package

**viega**

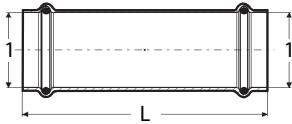

**Viega ProPress Extended Coupling Copper P x P - Model 2915.5**

Part No.	Size		L (in)
	1	2	
79005	1/2"		2.99
79010	3/4"		3.50
79015	1"		3.74
79020	1 1/4"		4.13
79025	1 1/2"		4.72
79030	2"		5.31

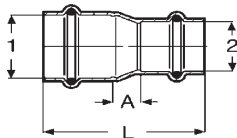

**Viega ProPress Reducer Copper P x P - Model 2915.2**

Part No.	Size		A (in)	L (in)
	1	2		
78147	3/4"	1/2"	0.42	2.07
15603	1"	1/2"	0.71	2.36
78152	1"	3/4"	0.48	2.29
15593	1 1/4"	3/4"	0.70	2.64
78157	1 1/4"	1"	0.55	2.48
18473	1 1/2"	3/4"	0.98	3.33
15588	1 1/2"	1"	0.74	3.07
78162	1 1/2"	1 1/4"	0.50	2.96
18468	2"	3/4"	1.54	4.02
15608	2"	1"	1.29	3.78
22328	2"	1 1/4"	0.81	3.43
78167	2"	1 1/2"	0.74	3.75

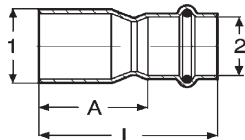

**Viega ProPress Reducer Copper FTG x P - Model 2915.1**

Part No.	Size		A (in)	L (in)
	1	2		
78077	3/4"	1/2"	1.42	2.17
78082	1"	1/2"	1.69	2.44
78087	1"	3/4"	1.42	2.32
22333	1 1/4"	1/2"	1.89	2.64
78092	1 1/4"	3/4"	1.85	2.76
78097	1 1/4"	1"	1.57	2.48
14543	1 1/2"	3/4"	2.56	3.46
78102	1 1/2"	1"	2.28	3.19
78107	1 1/2"	1 1/4"	2.04	3.07
78112	2"	1"	3.03	3.94
78117	2"	1 1/4"	2.79	3.82
78122	2"	1 1/2"	2.63	4.06

# Submittal Package

**viega**

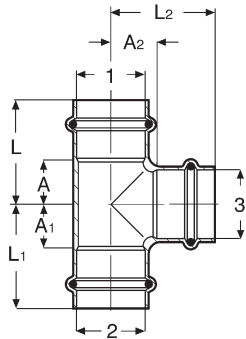

Viega ProPress Tee Copper P x P x P - Model 2918

Part No.	Size			A (in)	A1 (in)	A2 (in)	L (in)	L1 (in)	L2 (in)
	1	2	3						
77377	1/2"			0.75	0.75	0.50	1.50	1.50	1.25
77382	1/2" x 1/2" x 3/4"			0.91	0.91	0.59	1.65	1.65	1.50
15493	1/2" x 1/2" x 1"			1.10	1.10	0.55	1.85	1.85	1.46
77387	3/4"			0.85	0.85	0.59	1.75	1.75	1.50
77392	3/4" x 1/2" x 1/2"			0.69	0.98	0.63	1.59	1.73	1.38
77397	3/4" x 1/2" x 3/4"			0.85	1.14	0.59	1.75	1.89	1.50
77402	3/4" x 3/4" x 1/2"			0.69	0.69	0.63	1.59	1.59	1.38
77407	3/4" x 3/4" x 1"			0.97	0.97	0.63	1.87	1.87	1.54
77412	1"			0.97	0.97	0.79	1.87	1.87	1.69
22263	1" x 1/2" x 3/4"			0.85	1.24	0.75	1.76	1.99	1.66
94767	1" x 1/2" x 1"			0.97	1.52	0.79	1.87	2.26	1.69
77417	1" x 3/4" x 1/2"			0.69	0.89	0.79	1.59	1.79	1.54
77422	1" x 3/4" x 3/4"			0.85	1.04	0.75	1.75	1.95	1.65
77427	1" x 3/4" x 1"			0.97	1.18	0.78	1.87	2.07	1.69
77432	1" x 1" x 1/2"			0.69	0.69	0.79	1.59	1.59	1.54
77437	1" x 1" x 3/4"			0.85	0.85	0.75	1.75	1.75	1.65
15488	1" x 1" x 1 1/4"			1.16	1.16	0.84	2.07	2.07	1.87
77442	1 1/4"			1.02	1.02	0.86	2.05	2.05	1.89
22253	1 1/4" x 1/2" x 1 1/4"			1.02	1.77	0.87	2.05	2.52	1.89
22243	1 1/4" x 3/4" x 1/2"			0.64	1.13	0.93	1.68	2.03	1.68
22258	1 1/4" x 3/4" x 3/4"			0.76	1.30	0.87	1.80	2.21	1.78
22268	1 1/4" x 3/4" x 1"			0.88	1.40	0.91	1.91	2.31	1.82
22248	1 1/4" x 3/4" x 1 1/4"			1.02	1.54	0.86	2.05	2.45	1.89
22238	1 1/4" x 1" x 1/2"			0.64	0.91	0.93	1.68	1.82	1.68
94762	1 1/4" x 1" x 3/4"			0.76	1.14	0.87	1.79	2.05	1.77
14568	1 1/4" x 1" x 1"			0.88	1.28	0.91	1.91	2.19	1.81
94757	1 1/4" x 1 1/4" x 1/2"			0.65	0.65	0.93	1.67	1.67	1.67
77452	1 1/4" x 1 1/4" x 3/4"			0.77	0.77	0.89	1.79	1.79	1.77
77447	1 1/4" x 1 1/4" x 1"			0.88	0.88	0.90	1.91	1.91	1.81
77457	1 1/2"			1.13	1.13	1.13	2.56	2.56	2.56
79660	1 1/2" x 1" x 3/4"			0.67	1.39	1.16	2.17	2.44	2.05
15458	1 1/2" x 1" x 1"			0.74	1.54	1.06	2.17	2.44	1.97
15463	1 1/2" x 1" x 1 1/2"			1.13	1.83	1.13	2.56	2.74	2.56
22233	1 1/2" x 1 1/4" x 3/4"			0.67	1.08	1.15	2.09	2.11	2.05
15453	1 1/2" x 1 1/4" x 1"			0.74	1.29	1.18	2.17	2.32	2.09
15483	1 1/2" x 1 1/4" x 1 1/4"			0.86	1.33	1.13	2.28	2.36	2.17
15448	1 1/2" x 1 1/2" x 1/2"			0.47	0.47	1.10	1.89	1.89	1.85
77462	1 1/2" x 1 1/2" x 3/4"			0.66	0.66	1.14	2.09	2.09	2.05
77467	1 1/2" x 1 1/2" x 1"			0.74	0.74	1.18	2.17	2.17	2.09
77472	1 1/2" x 1 1/2" x 1 1/4"			0.86	0.86	1.13	2.28	2.28	2.17
77477	2"			1.37	1.37	1.37	2.95	2.95	2.95
15518	2" x 1 1/4" x 1 1/4"			0.94	1.84	1.33	2.52	2.87	2.36
15513	2" x 1 1/2" x 3/4"			0.70	1.25	1.38	2.28	2.68	2.28
15498	2" x 1 1/2" x 1"			0.82	1.45	1.38	2.40	2.87	2.28
15508	2" x 1 1/2" x 1 1/4"			0.94	1.55	1.49	2.52	2.97	2.52

Continued on next page

# Submittal Package

**viega**

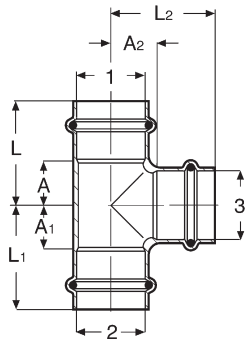

**Copper Tee P x P x P - Model 2918 (continued)**

Part No.	Size			A (in)	A1 (in)	A2 (in)	L (in)	L1 (in)	L2 (in)
	1	2	3						
15503	2" x 1½" x 1½"			1.13	1.65	1.37	2.72	3.07	2.80
22228	2" x 1½" x 2"			1.38	1.89	1.38	2.95	3.33	2.95
15538	2" x 2" x ½"			0.54	0.54	1.30	2.13	2.13	2.05
94777	2" x 2" x ¾"			0.79	0.79	1.26	2.37	2.37	2.17
94772	2" x 2" x 1"			0.91	0.91	1.30	2.49	2.49	2.21
77487	2" x 2" x 1¼"			1.04	1.04	1.37	2.62	2.62	2.40
77482	2" x 2" x 1½"			1.13	1.13	1.37	2.72	2.72	2.80

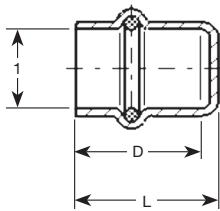

**Viega ProPress Cap Copper P - Model 2956**

Part No.	Size	L (in)	D (in)
	<b>1</b>		
77712	½"	0.92	0.79
77717	¾"	1.07	0.94
77722	1"	1.11	0.99
77727	1¼"	1.32	1.20
77732	1½"	1.62	1.49
77737	2"	1.81	1.69

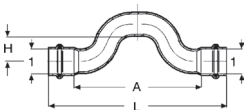

**Viega ProPress Cross-Over Copper P x P - Model 2928**

Part No.	Size	A (in)	L (in)	H (in)
	<b>1</b>			
77742	½"	3.62	5.12	0.77
77747	¾"	4.49	6.30	0.90

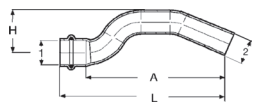

**Viega ProPress Cross-Over Copper P x FTG - Model 2927**

Part No.	Size		A (in)	L (in)	H (in)
	1	2			
78137	½" x ½"		3.83	4.58	1.10
78142	¾" x ¾"		4.64	5.54	1.54

# Submittal Package

**viega**



## Viega ProPress Adapter Zero Lead Bronze P x MPT - Model 2911ZL

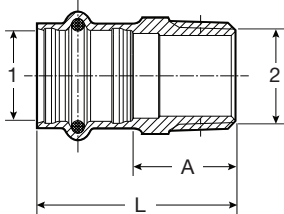

Part No.	Size	A (in)	L (in)
	1 2		
79210	1/2" x 3/8" MPT	0.77	1.59
79215	1/2" x 1/2" MPT	0.89	1.71
79220	1/2" x 3/4" MPT	1.00	1.83
79225	3/4" x 1/2" MPT	1.02	1.93
79230	3/4" x 3/4" MPT	1.02	1.93
79235	3/4" x 1" MPT	1.18	2.09
79240	1" x 3/4" MPT	1.18	2.09
79245	1" x 1" MPT	1.26	2.17
79250	1" x 1 1/4" MPT	1.54	2.44
79255	1 1/4" x 1" MPT	1.22	2.24
79260	1 1/4" x 1 1/4" MPT	1.34	2.36
79265	1 1/4" x 1 1/2" MPT	1.48	2.50
79270	1 1/2" x 1 1/4" MPT	1.34	2.76
79275	1 1/2" x 1 1/2" MPT	1.28	2.70
79280	1 1/2" x 2" MPT	1.65	3.07
79285	2" x 1 1/2" MPT	1.54	3.11
79290	2" x 2" MPT	1.50	3.07

## Viega ProPress Adapter Zero Lead Bronze P x FPT - Model 2912ZL

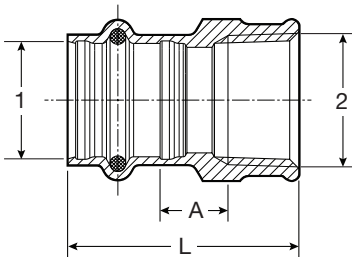

Part No.	Size	A (in)	L (in)
	1 2		
79295	1/2" x 3/8" FPT	0.19	1.42
79300	1/2" x 1/2" FPT	0.25	1.61
79305	1/2" x 3/4" FPT	0.27	1.65
79310	3/4" x 1/2" FPT	0.33	1.77
79315	3/4" x 3/4" FPT	0.35	1.81
79320	1" x 1/2" FPT	0.41	1.85
79325	1" x 3/4" FPT	0.39	1.85
79330	1" x 1" FPT	0.44	2.01
79335	1" x 1 1/4" FPT	0.50	2.09
79340	1 1/4" x 1/2" FPT	0.37	1.93
79345	1 1/4" x 1" FPT	0.24	1.93
79350	1 1/4" x 1 1/4" FPT	0.34	2.05
79355	1 1/4" x 1 1/2" FPT	0.42	2.13
79360	1 1/2" x 1 1/4" FPT	0.26	2.36
79365	1 1/2" x 1 1/2" FPT	0.34	2.44
79370	2" x 2" FPT	0.41	2.68

# Submittal Package

**viega**

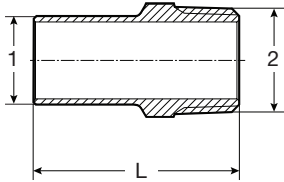

**Viega ProPress Adapter Zero Lead Bronze FTG x MPT - Model 2911.1ZL**

Part No.	Size		L (in)
	1	2	
79375	1/2"	3/8" MPT	1.75
79380	1/2"	1/2" MPT	1.95
79385	1/2"	3/4" MPT	2.05
79390	3/4"	1/2" MPT	1.93
79395	3/4"	3/4" MPT	2.05
79400	1"	3/4" MPT	2.05
79405	1"	1" MPT	2.22
79410	1 1/4"	1 1/4" MPT	2.54
79415	1 1/2"	1 1/2" MPT	2.89
79420	2"	2" MPT	3.33

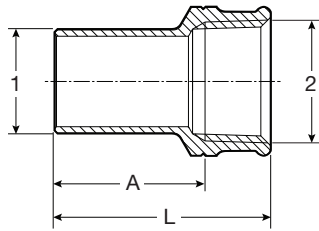

**Viega ProPress Adapter Zero Lead Bronze FTG x FPT - Model 2912.1ZL**

Part No.	Size		A (in)	L (in)
	1	2		
79425	1/2"	3/8" FPT	1.10	1.54
79430	1/2"	1/2" FPT	1.22	1.75
79435	1/2"	3/4" FPT	1.30	1.83
79440	3/4"	1/2" FPT	1.26	1.79
79445	3/4"	3/4" FPT	1.28	1.83
79455	1"	1/2" FPT	1.35	1.99
79450	1"	1" FPT	1.33	1.99
79460	1 1/4"	1/2" FPT	1.65	2.19
79465	1 1/4"	1 1/4" FPT	1.50	2.19
79470	1 1/2"	1 1/2" FPT	1.88	2.56
79475	2"	2" FPT	2.13	2.95

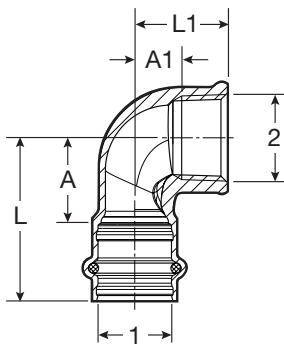

**Viega ProPress 90° Elbow Zero Lead Bronze P x FPT - Model 2914.2ZL**

Part No.	Size		A (in)	A1 (in)	L (in)	L1 (in)
	1	2				
79520	1/2"	3/8" FPT	0.94	0.42	1.77	0.83
79525	1/2"	1/2" FPT	0.94	0.57	1.77	1.10
79530	1/2"	3/4" FPT	1.06	0.51	1.89	1.06
79535	3/4"	1/2" FPT	1.06	0.65	1.97	1.18
79540	3/4"	3/4" FPT	1.06	0.57	1.97	1.12
79545	1"	1/2" FPT	1.06	0.72	1.97	1.26
79550	1"	1" FPT	1.34	0.76	2.24	1.42
79560	1 1/4"	1 1/4" FPT	1.54	0.89	2.56	1.57
79565	1 1/2"	1 1/2" FPT	1.69	1.05	3.11	1.73
79570	2"	2" FPT	2.17	1.35	3.74	2.05

# Submittal Package

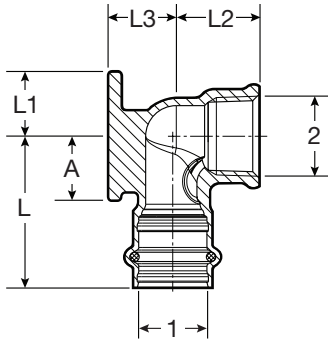

**Viega ProPress 90° Drop Ear Elbow Zero Lead Bronze P X FPT - Model 2925.5ZL**

Part No.	Size		A (in)	L (in)	L1 (in)	L2 (in)	L3 (in)
	1	2					
79185	1/2"	3/8" FPT	0.94	1.77	0.74	0.83	0.67
79190	1/2"	1/2" FPT	0.94	1.77	0.74	1.10	0.67
79195	3/4"	3/4" FPT	1.06	1.97	0.83	1.12	0.83

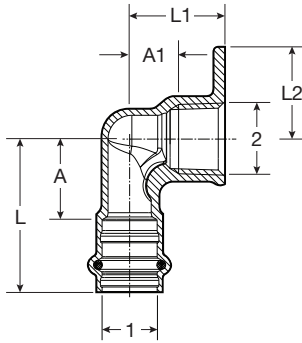

**Viega ProPress 90° Hi Ear Elbow Zero Lead Bronze P x FPT - Model 2925.2ZL**

Part No.	Size		A (in)	A1 (in)	L (in)	L1 (in)	L2 (in)
	1	2					
79205	1/2"	1/2" FPT	0.94	0.57	1.77	1.10	1.07

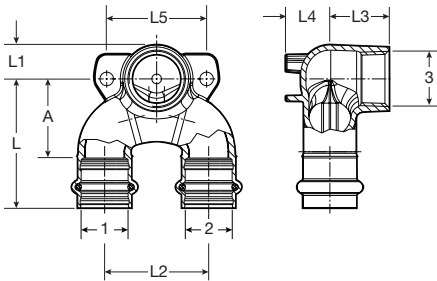

**Viega ProPress Double Drop Elbow Zero Lead Bronze P x P x FPT - Model 2928.7ZL**

Part No.	Size			A (in)	L (in)	L2 (in)	L3 (in)	L4 (in)	L5 (in)
	1	2	3						
78800	1/2"	1/2"	1/2" FNPT	1.34	2.17	1.97	1.10	0.67	1.57
78801	3/4"	3/4"	3/4" FNPT	1.54	2.44	1.97	1.12	0.83	1.89
78802	3/4"	3/4"	1/2" FNPT	1.54	2.44	1.97	1.10	0.83	2.05
78803	1"	1"	1/2" FNPT	1.77	2.68	2.36	1.10	0.87	2.52

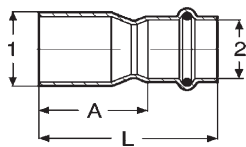

**Viega ProPress Reducer Zero Lead Bronze FTG x P - Model 2915.1ZL**

Part No.	Size		A (in)	L (in)
	1	2		
79850	1 1/2"	1 1/2"	1.95	2.78
79855	2"	1 1/2"	2.38	3.21
79860	2"	3/4"	2.42	3.33

# Submittal Package

**viega**



## Viega ProPress Tee Zero Lead Bronze P x P x FPT - Model 2917.2ZL

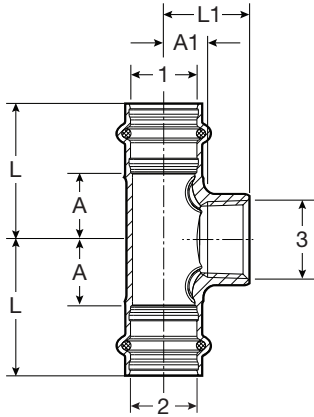

Part No.	Size			A (in)	A1 (in)	L (in)	L1 (in)
	1	2	3				
79580	1/2"	1/2"	1/2"	0.79	0.69	1.61	1.30
79585	3/4"	3/4"	1/4"	0.67	0.79	1.57	1.18
79590	3/4"	3/4"	1/2"	0.79	0.88	1.69	1.42
79595	3/4"	3/4"	3/4"	0.91	0.59	1.81	1.14
79760	1"	1"	1/2"	0.79	1.04	1.69	1.57
79765	1"	1"	3/4"	0.91	1.06	1.81	1.61
79770	1 1/4"	1 1/4"	1/2"	0.83	1.16	1.85	1.69
79775	1 1/4"	1 1/4"	3/4"	0.95	1.18	1.97	1.73
79780	1 1/2"	1 1/2"	1/2"	0.87	1.24	2.28	1.77
79785	1 1/2"	1 1/2"	3/4"	0.94	1.30	2.36	1.85
79790	2"	2"	1/2"	0.98	1.59	2.56	2.13
79795	2"	2"	3/4"	1.06	1.65	2.64	2.20

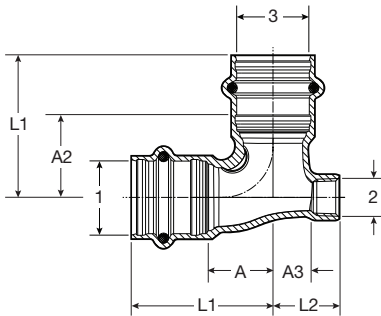

## Viega ProPress Tee Vent Zero Lead Bronze P x FPT x P - Model 2917.3ZL

Part No.	Size			A (in)	A2 (in)	A3 (in)	L (in)	L1 (in)	L2 (in)
	1	2	3						
79635	1/2"	1/8"	1/2"	0.67	0.67	0.44	1.50	1.50	0.71
79640	3/4"	1/8"	3/4"	0.83	0.83	0.54	1.73	1.73	0.81

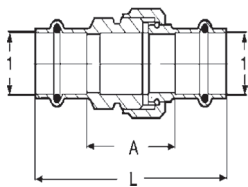

## Viega ProPress Union Zero Lead Bronze P x P - Model 2960ZL

Part No.	Size		A (in)	L (in)
	1			
79125	1/2"		1.19	2.84
79130	3/4"		1.34	3.15
79135	1"		1.83	3.65
79140	1 1/4"		1.64	3.69
79145	1 1/2"		2.13	4.96
79150	2"		2.07	5.22

# Submittal Package

**viega**

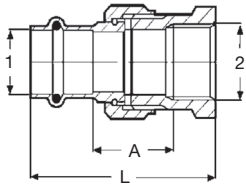

**Viega ProPress Union Zero Lead Bronze P x FPT - Model 2962ZL**

Part No.	Size		A (in)	L (in)
	1	2		
79700	1/2"	1/2" FPT	0.91	2.27
79705	3/4"	3/4" FPT	0.96	2.42
79710	1"	1" FPT	1.31	2.88
79715	1 1/4"	1 1/4" FPT	1.27	2.97
79720	1 1/2"	1 1/2" FPT	1.77	3.87
79725	2"	2" FPT	1.65	3.92

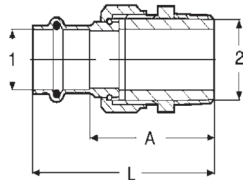

**Viega ProPress Union Zero Lead Bronze P x MPT - Model 2965ZL**

Part No.	Size		A (in)	L (in)
	1	2		
79730	1/2"	1/2" MPT	1.86	2.69
79735	3/4"	3/4" MPT	2.00	2.90
79740	1"	1" MPT	2.54	3.45
79745	1 1/4"	1 1/4" MPT	2.49	3.52
79750	1 1/2"	1 1/2" MPT	3.05	4.47
79755	2"	2" MPT	2.99	4.57

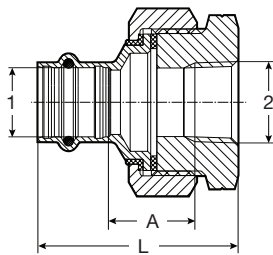

**Viega ProPress Union Zero Lead Bronze P x FPT - Model 2967ZL**

Part No.	Size		A (in)	L (in)
	1	2		
79155	1/2"	1/2" FPT	0.88	2.24
79160	3/4"	3/4" FPT	1.11	2.57
79165	1"	1" FPT	1.00	2.57
79170	1 1/4"	1 1/4" FPT	0.97	2.68
79175	1 1/2"	1 1/2" FPT	1.01	3.11
79180	2"	2" FPT	1.26	3.53

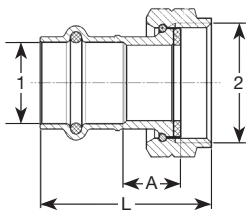

**Viega ProPress Tailpiece Zero Lead Bronze P x F BSP - Model 2957ZL**

Part No.	Size		A (in)	L (in)
	1	2		
79800	1/2"	1" BSP	0.39	1.57
79805	3/4"	1" BSP	0.63	1.87
79810	1"	1" BSP	0.91	2.14
79815	1"	1 1/4" BSP	0.73	2.04

# Submittal Package

**viega**

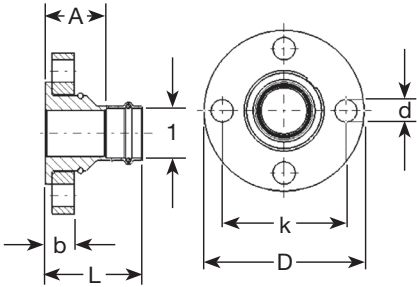

**Viega ProPress Adapter Flange Zero Lead Bronze P x Flange - Model 2959.5ZL**

Part No.	Size	L (in)	A (in)	b (in)	D (in)	k (in)	d (in)
	<b>1</b>						
79680	1"	2.76	1.85	0.84	4.33	3.11	0.63
79685	1¼"	2.76	1.73	0.84	4.53	3.50	0.63
79690	1½"	3.07	1.65	0.84	4.92	3.86	0.63
79695	2"	3.66	2.09	0.84	5.91	4.76	0.75

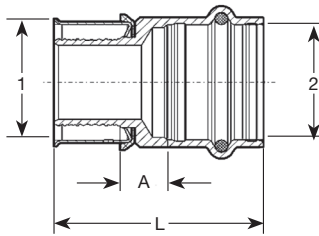

**Viega PEX Press Adapter Zero Lead Bronze P x P - Model 2813PZL**

Part No.	Size	A (in)	L (in)
	<b>1 2</b>		
99620	½" x ½"	0.29	1.61
99626	½" x ¾"	0.43	1.83
99630	¾" x ½"	0.23	1.56
99640	¾" x ¾"	0.33	1.73
99660	1" x 1"	0.45	1.97
99670	1¼" x 1¼"	0.49	2.38
99680	1½" x 1½"	0.59	2.87
99690	2" x 2"	0.58	3.21

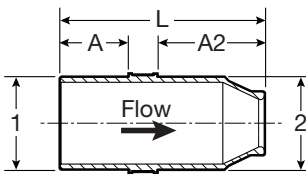

**Viega ProPress Venturi Insert Zero Lead Bronze - Model 2911.5ZL**

Part No.	Size	A (in)	A2 (in)	L (in)
	<b>1 2</b>			
78810	1¼" x 1¼"	1.02	1.60	3.07
78811	1½" x 1½"	1.43	2.10	3.98
78812	2" x 2"	1.58	2.45	4.48

# Submittal Package

**viega**

## ProPress® XL (Copper) Dimensional Documentation

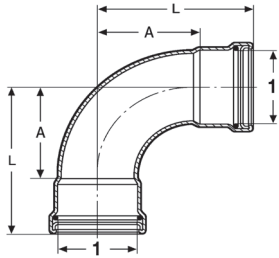

**XL 90° Elbow P x P - Model 0916XL**

Part Number	Size	A (in)	L (in)
	<b>1</b>		
20623	2½"	3.19	4.88
20628	3"	3.76	5.73
20633	4"	4.90	7.26

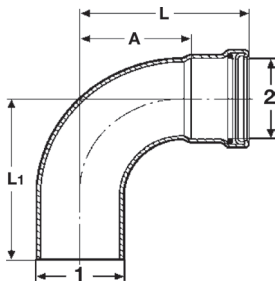

**XL 90° Street Elbow P x FTG - Model 0916.1XL**

Part Number	Size	A (in)	L (in)	L1 (in)
	<b>1 2</b>			
20638	2½" x 2½"	3.19	4.88	4.80
20643	3" x 3"	3.76	5.73	5.63
20648	4" x 4"	4.90	7.26	7.13

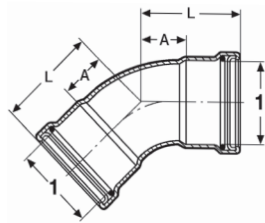

**XL 45° P x P - Model 0926XL**

Part Number	Size	A (in)	L (in)
	<b>1</b>		
20653	2½"	1.48	3.18
20658	3"	1.73	3.70
20663	4"	1.96	4.63

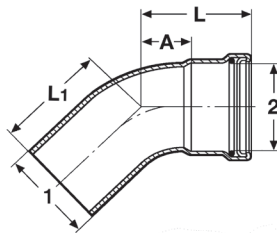

**XL 45° Street Elbow P x FTG - Model 0926.1XL**

Part Number	Size	A (in)	L (in)	L1 (in)
	<b>1 2</b>			
20668	2½" x 2½"	1.48	3.18	3.10
20673	3" x 3"	1.73	3.70	3.60
20678	4" x 4"	2.23	4.59	4.45

# Submittal Package

**viega**

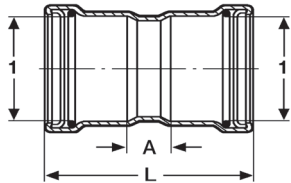

**XL Coupling with Stop P x P - Model 0915XL**

Part Number	Size	A (in)	L (in)
	1		
20728	2½"	0.95	4.33
20733	3"	0.98	4.92
20738	4"	1.06	5.79

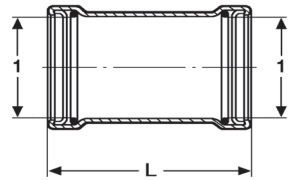

**XL Coupling No Stop P x P - Model 0915.5XL**

Part Number	Size	L (in)
	1	
20743	2½"	4.33
20748	3"	4.92
20753	4"	5.79

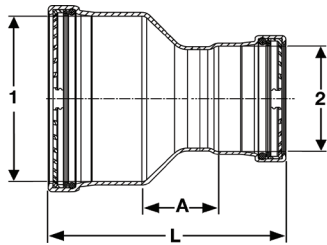

**XL Reducer P x P - Model 0915.2XL**

Part Number	Size	A (in)	L (in)
	1 2		
20685	2½" x 1"	1.76	4.36
20690	2½" x 1¼"	1.61	4.34
20695	2½" x 1½"	1.52	4.64
20700	2½" x 2"	1.41	4.69
20705	3" x 1½"	1.78	5.17
20710	3" x 2"	1.53	5.08
20715	3" x 2½"	1.41	5.07
20720	4" x 2"	2.06	6.00
20725	4" x 2½"	1.93	5.99
20730	4" x 3"	1.70	6.03

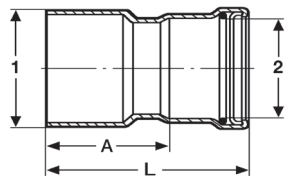

**XL Reducer FTG x P - Model 0915.1XL**

Part Number	Size	A (in)	L (in)
	1 2		
20814	2½" x 1"	3.61	4.52
20815	2½" x 1¼"	3.47	4.51
20813	2½" x 1½"	3.41	4.84
20758	2½" x 2"	2.35	3.94
20817	3" x 1¼"	3.96	5.00
20818	3" x 1½"	3.91	5.34
20763	3" x 2"	2.98	4.57
20768	3" x 2½"	2.76	4.45
20773	4" x 2"	4.58	6.17
20778	4" x 2½"	4.45	6.15
20783	4" x 3"	4.17	6.14

# Submittal Package

**viega**

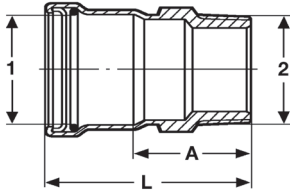

**XL Adapter P x MPT - Model 0911XL**

Part Number	Size	A (in)	L (in)
	1 2		
20823	2½" x 2½" MPT	2.76	4.45
20828	3" x 3" MPT	2.84	4.80
20838	4" x 4" MPT	3.10	5.46

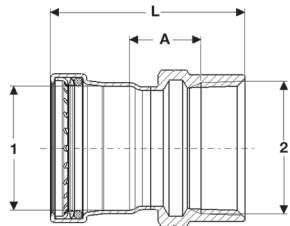

**XL Adapter P x FPT - Model 0912XL**

Part Number	Size	A (in)	L (in)
	1 2		
20819	2½" x 2½" FPT	1.53	4.15
20829	3" x 3" FPT	1.84	4.82
20839	4" x 4" FPT	2.09	5.55

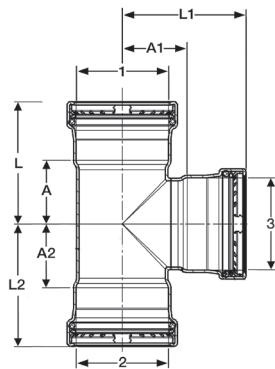

**XL Tee P x P x P - Model 0918XL**

Part Number	Size	A (in)	A1 (in)	A2 (in)	L (in)	L1 (in)	L2 (in)
	1 2 3						
20684	2½" x ¾" x 2½"	1.83	1.91	3.23	3.52	3.60	4.13
20689	2½" x 1" x 2½"	1.83	1.91	3.25	3.52	3.60	4.15
20694	2½" x 1¼" x 2½"	1.83	1.91	3.20	3.52	3.60	4.23
20699	2½" x 1½" x 2½"	1.83	1.91	3.14	3.52	3.60	4.57
20704	2½" x 2" x ¾"	1.04	1.61	1.59	2.74	2.52	3.17
20709	2½" x 2" x 1"	1.04	1.77	1.65	2.74	2.67	3.24
22283	2½" x 2" x 1½"	1.30	1.78	2.07	2.99	3.20	3.66
22278	2½" x 2" x 2"	1.50	1.78	2.25	3.19	3.36	3.83
20714	2½" x 2" x 2½"	1.83	1.91	2.41	3.52	3.60	4.00
22303	2½" x 2½" x ½"	0.91	1.52	0.91	2.60	2.27	2.60
22298	2½" x 2½" x ¾"	0.91	1.58	0.91	2.60	2.48	2.60
22293	2½" x 2½" x 1"	1.04	1.77	1.04	2.74	2.68	2.74
22288	2½" x 2½" x 1¼"	1.16	1.76	1.16	2.85	2.79	2.85
20803	2½" x 2½" x 1½"	1.30	1.78	1.30	2.99	3.21	2.99
20688	2½" x 2½" x 2"	1.54	1.75	1.54	3.23	3.34	3.23
20683	2½" x 2½" x 2½"	1.83	1.87	1.83	3.52	3.57	3.52
20719	3" x ¾" x 3"	2.07	2.15	3.82	4.04	4.11	4.72
20724	3" x 1" x 3"	2.07	2.15	3.96	4.04	4.11	4.86
20729	3" x 1¼" x 3"	2.07	2.15	3.83	4.04	4.11	4.86

Continued on next page

# Submittal Package

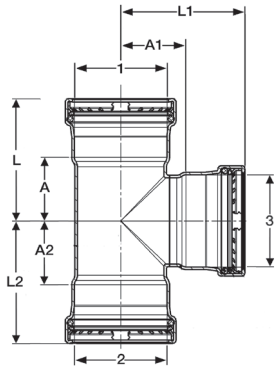

XL Tee P x P x P - Model 0918XL (continued from previous page)

Part Number	Size	A (in)	A1 (in)	A2 (in)	L (in)	L1 (in)	L2 (in)
	1 2 3						
20727	3" x 1½" x 3"	2.07	2.15	3.71	4.04	4.11	5.14
20732	3" x 2" x 2"	1.56	2.03	2.33	3.52	3.61	3.92
20734	3" x 2" x 2½"	1.85	2.15	2.63	3.82	3.85	4.21
20739	3" x 2" x 3"	2.07	2.15	2.84	4.04	4.11	4.43
20744	3" x 2½" x 2"	1.56	2.03	2.07	3.52	3.61	3.76
20749	3" x 2½" x 2½"	1.85	2.15	2.56	3.82	3.85	4.25
20754	3" x 2½" x 3"	2.07	2.15	2.78	4.04	4.11	4.47
20759	3" x 3" x ½"	0.93	1.76	0.93	2.89	2.50	2.89
22323	3" x 3" x ¾"	0.93	1.80	0.93	2.89	2.71	2.89
22308	3" x 3" x 1"	1.06	2.02	1.06	3.03	2.92	3.03
22313	3" x 3" x 1¼"	1.18	2.01	1.18	3.15	3.04	3.15
20798	3" x 3" x 1½"	1.32	2.03	1.32	3.29	3.45	3.29
20698	3" x 3" x 2"	1.56	2.00	1.56	3.52	3.59	3.52
20703	3" x 3" x 2½"	1.85	2.15	1.85	3.82	3.85	3.82
20693	3" x 3" x 3"	2.07	2.21	2.07	4.04	4.18	4.04
20774	4" x 3" x 2"	1.59	2.57	3.33	3.96	4.15	5.22
20784	4" x 3" x 3"	2.11	2.66	3.84	4.47	4.63	5.81
20788	4" x 4" x ½"	1.08	2.24	1.08	3.45	2.99	3.45
20793	4" x 4" x ¾"	1.08	2.32	1.08	3.45	3.22	3.45
20794	4" x 4" x 1"	1.36	2.52	1.36	3.72	3.42	3.72
20795	4" x 4" x 1¼"	1.36	2.50	1.36	3.72	3.54	3.72
20808	4" x 4" x 1½"	1.36	2.52	1.36	3.72	3.95	3.72
20713	4" x 4" x 2"	1.59	2.53	1.59	3.96	4.11	3.96
20718	4" x 4" x 2½"	1.89	2.65	1.89	4.25	4.35	4.25
20723	4" x 4" x 3"	2.11	2.69	2.11	4.47	4.65	4.47
20708	4" x 4" x 4"	2.60	2.72	2.60	4.96	5.09	4.96

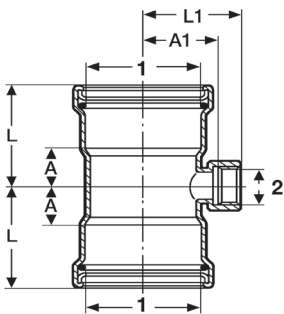

XL Tee P x P x FPT - Model 0917.2XL

Part Number	Size	A (in)	A1 (in)	L (in)	L1 (in)
	1 2				
20883	2½" x ¾" FPT	1.02	1.78	2.72	2.34
20878	2½" x 2" FPT	1.54	1.90	3.23	2.60
20893	3" x ¾" FPT	1.04	2.03	3.01	2.59
20888	3" x 2" FPT	1.56	2.16	3.52	2.85
20873	4" x ¾" FPT	1.08	2.53	3.34	3.09
20868	4" x 2" FPT	1.59	2.69	3.96	3.38

# Submittal Package

**viega**

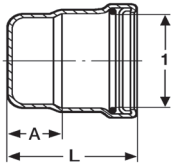

**XL Cap P - Model 0956XL**

Part Number	Size	A (in)	L (in)
	1		
20833	2½"	0.39	2.11
20843	3"	0.39	2.36
20848	4"	0.39	2.76

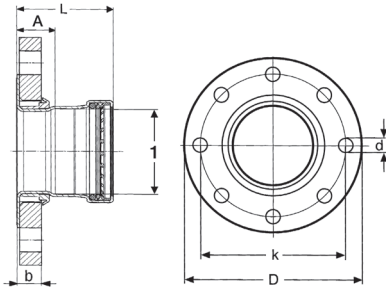

**XL Adapter Flange P x Flange - Model 0959.5XL**

Part Number	Size	A (in)	L (in)	b (in)	k (in)	D (in)	d (in)
	1						
20853	2½"	1.09	2.79	0.70	5.51	7.09	0.75
20858	3"	1.20	3.17	0.79	5.98	7.48	0.75
20863	4"	1.29	3.66	0.86	7.52	9.06	0.75

# Submittal Package

**viega**

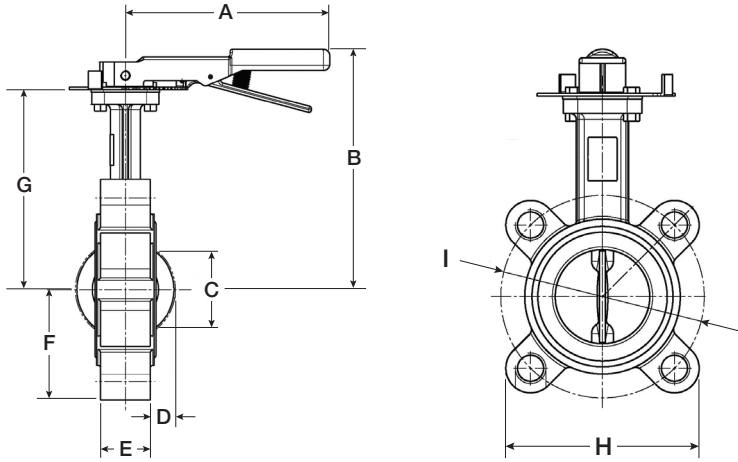

**Butterfly Valve - Model 2873.81**

Part No.	Size	A (in)	B (in)	C (in)	D (in)	E (in)	F (in)	G (in)	H (in)	I (in)
22074	2½"	6.50	7.40	2.17	0.43	1.81	2.64	5.35	5.20	5.51
22075	3"	7.28	7.64	2.80	0.67	1.81	2.82	5.59	7.01	5.98

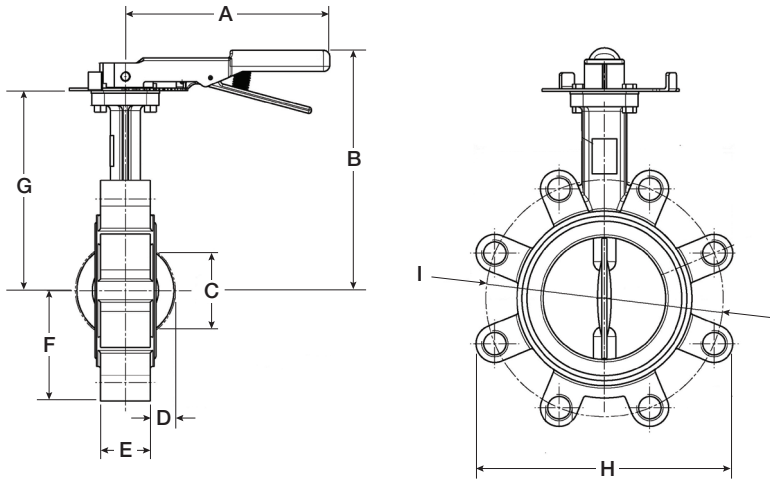

**Butterfly Valve - Model 2873.81**

Part No.	Size	A (in)	B (in)	C (in)	D (in)	E (in)	F (in)	G (in)	H (in)	I (in)
22076	4"	9.06	8.47	3.54	0.91	2.05	3.62	6.42	8.27	7.48

# Submittal Package

**viega**

## Viega Limited Warranty ProPress® Fittings And Valves

Subject to the conditions and limitations in this Limited Warranty, Viega LLC (VIEGA) warrants to wholesalers and licensed plumbing and mechanical contractors in the United States and Canada that its PROGRESS fittings, when properly installed in non industrial and non marine applications and under normal conditions of use, will be free of failure from manufacturing defect for a period of fifty (50) years from date of installation and that its PROGRESS valves, when properly installed in non industrial and non marine applications and under normal conditions of use, will be free of failure from manufacturing defect for a period of two (2) years from date of installation.

Under this Limited Warranty, you only have a right to a remedy if the failure or leak resulted from a manufacturing defect in the products covered by this warranty and the failure or leak occurred during the warranty period. You do not have a remedy under this warranty and the warranty does not apply if the failure or any resulting damage is caused by (1) components other than those manufactured or sold by Viega; (2) not designing, installing, inspecting, or testing the ProPress fittings or valves in accordance with Viega's installation instructions in effect at the time of the installation; applicable code requirements; and accepted industry practice; (3) improper handling and protection of the product prior to and during installation, inadequate freeze protection, exposure to water pressures or temperatures or in applications outside acceptable operating conditions; (4) acts of nature such as, but not limited to, earthquakes, fire, flood, or lightning, or (5) external environmental causes, such as water quality variations, aggressive water, or other external chemical or physical conditions.

In the event of a leak or other failure of the parts covered by this warranty, it is the responsibility of the property owner to obtain and pay for repairs. Only if the warranty applies will Viega be responsible for the remedy under this

warranty. The part or parts which you claim failed should be kept and Viega contacted by writing to the address below or telephoning 1-800-976-9819 within thirty (30) days after the leak or other failure and identifying yourself as having a warranty claim. You should be prepared to ship, at your expense, the product which you claim failed due to a manufacturing defect and document the date of installation. Within a reasonable time after receiving the product, Viega will investigate the reasons for the failure, which includes the right to inspect the product at Viega. Viega will notify you in writing of the results of its review.

In the event that Viega determines that the failure or leak was the result of a manufacturing defect in the part covered by this warranty and that this warranty applies, the EXCLUSIVE AND ONLY REMEDY under this warranty shall be the reimbursement for repair and/or replacement of the part. VIEGA SHALL NOT BE LIABLE FOR ANY CONSEQUENTIAL OR OTHER DAMAGE (FOR EXAMPLE, WATER OR PROPERTY OR MOLD REMEDIATION) UNDER ANY LEGAL THEORY AND WHETHER ASSERTED BY DIRECT ACTION, FOR CONTRIBUTION OR INDEMNITY OR OTHERWISE.

THE ABOVE WARRANTY IS IN LIEU OF ALL OTHER WARRANTIES, EXPRESS OR IMPLIED, INCLUDING BUT NOT LIMITED TO THE IMPLIED WARRANTIES OF MERCHANTABILITY AND FITNESS FOR A PARTICULAR PURPOSE. If a limited warranty shall be found to apply, such warranty is limited to four years. Other than this Limited Warranty, Viega does not authorize any person or firm to create for it any other obligation or liability in connection with its products.

This Limited Warranty gives you specific legal rights and you also may have other rights which may vary from state to state. This warranty shall be interpreted and applied under the law of the state in which the product is installed and is intended as a Commercial Warranty.

\*Zero Lead identifies Viega® products meeting the lead free requirements of NSF 61-G through testing under NSF/ANSI 372 (0.25% or less maximum weighted average lead content).

This document subject to updates. For the most current Viega technical literature please visit [www.viega.us](http://www.viega.us).  
Click Services -> Click Electronic Literature Downloads -> Select Product Line -> Select Desired Document

**Viega LLC, 100 N. Broadway, 6<sup>th</sup> Floor • Wichita, KS 67202 • Ph: 800-976-9819 • Fax: 316-425-7618**



**WORTHINGTON**  
CYLINDERS  
A Worthington Industries Company

## ***Worthington Petroleum Based Flux***

*Issued: 10/15/13*

### **Certificate of Conformance**

This is to certify that WORTHINGTON Petroleum Based Flux is made per the formulation shown below. This flux is certified to be lead free per ANSI/NSF 61.

### **Composition**

INGREDIENT	CAS NO.	COMPOSITION
Petrolatum	8009-03-8	55% – 85%
Zinc Chloride	7646-85-7	15% – 40%
Ammonium Chloride	12125-02-9	0% – 5%



WORTHINGTON PetroleumBasedFlux CofC  
Rev. 000  
Date: 10/15/2013



## ***Solder-Safe 95/5 Lead-Free Solder***

### **Certificate of Conformance**

This is to certify that WORTHINGTON Solder-Safe 95/5 Tin-Antimony solder is lead-free. Meets or exceeds the requirements for lead-free plumbing solder set forth in the Federal Safe Drinking Water Act Amendments of June 19, 1986. This solder is manufactured per composition ASTM B-32 Alloy Grade Sb5.

### **NOMINAL COMPOSITION & TYPICAL PROPERTIES**

**Tin (Sn): 95.0%      Tensile Strength      5500psi**

**Antimony (Sb): 4.5-5.0%      Shear Strength      6000psi**

**Temperature (solidus): 450°F**

**Temperature (liquidus): 464°F**



Made in U.S.A.  
with global components